

**Elecnova**

# Digital Intelligent

Power Distribution Solution

JIANGSU SFERE ELECTRIC CO., LTD.

**JIANGSU SFERE ELECTRIC CO., LTD.**

Add: No.1 Dongding Road, Jiangyin, Jiangsu, China

Tel: +86-510-86199063

E-mail: [export@sfere-elec.com](mailto:export@sfere-elec.com)

<http://www.sfere-elec.net>



Version: EN.S.2307



# CONTENTS

## 01 COMPANY PROFILE

01-05 Corporate Culture  
R&D and Innovation  
Modern Management  
Brand Strength  
Product Overview

## 02 DEVICES

### 07-36 MULTI-FUNCTIONAL POWER METER

Sfere720 Series  
PD194Z-9HY  
PD194Z-9TY  
LNF Series  
PD194Z-E200

### 38-50 DIN RAIL MOUNTED ENERGY METER

S36  
DDS/DSS/DTS1946 Series

### 52-64 MULTI-CIRCUIT MONITORING SYSTEM

Sfere701  
BCM101  
PD194Z-E14

### 66-77 ENERGY METER FOR EV CHARGER

PD195Z-CD31F  
PD195Z-CD32F  
DTSF1946-4M-01  
DDSF1946-2M

### 79-84 DC MULTI-FUNCTIONAL POWER METER

PD195E-5SY1  
PD195Z-E33

### 86-92 DIGITAL POWER METER

LNF90 Series  
LNF70 Series

### 94-98 SMART MODULE

Sfere700-TM / Sfere700-TS  
Sfere700-DI3

### 100-101 BUSWAY TEMPERATURE MONITORING SYSTEM

Sfere702

### 103-121 MOTOR PROTECTION CONTROLLER

WDH-31-200  
WDH-31-530  
WDH-31-580

## 03 COMMUNICATION

123-128 S20  
S15  
SC2

## 04 MONITORING AND MANAGEMENT

129-133 EIOP  
PMS  
NPMS  
EMS

## 05 PROJECTS



## ■ ABOUT US

As the leading digital power distribution solution provider, Sfero Electric are dedicating on systematic solutions of energy management, power monitoring, power quality, electrical safety and intelligent switchgear to smart grid users. Our businesses focus on smart building, utility, large-scale industrial enterprise, renewable energy, semiconductor, IDC, advanced material, petrochemical, transportation infrastructure, education and health care industries.

Sfero Electric integrate R&D, manufacturing, marketing and service, and have a complete product ecosystem from digital measuring terminals, intelligent switchgear to IoT Cloud platform. We provide reliable data services for energy saving, electrical safety and comprehensive energy management to empower smart energy management by digitization.

## ■ CORPORATE CULTURE

### Core Values

- Create value for customers
- Share value with employees
- Contribute value to community

### Corporate Vision

Build Sfero Electric as a top domestic supplier of power products and services focusing on comprehensive power applications.

### Enterprise Spirit

- Unity in a concerted effort
- Honesty
- Intelligence, innovation
- Scientific development





Sfere Electric have participated in the formulation of a number of national and industrial standards; Hundreds of patents and more than 100 software copyrights have been gained by us; One of the first national intellectual property demonstration enterprises has been won by us. Our products passed CE, MID, UL and Russian metrological certification.

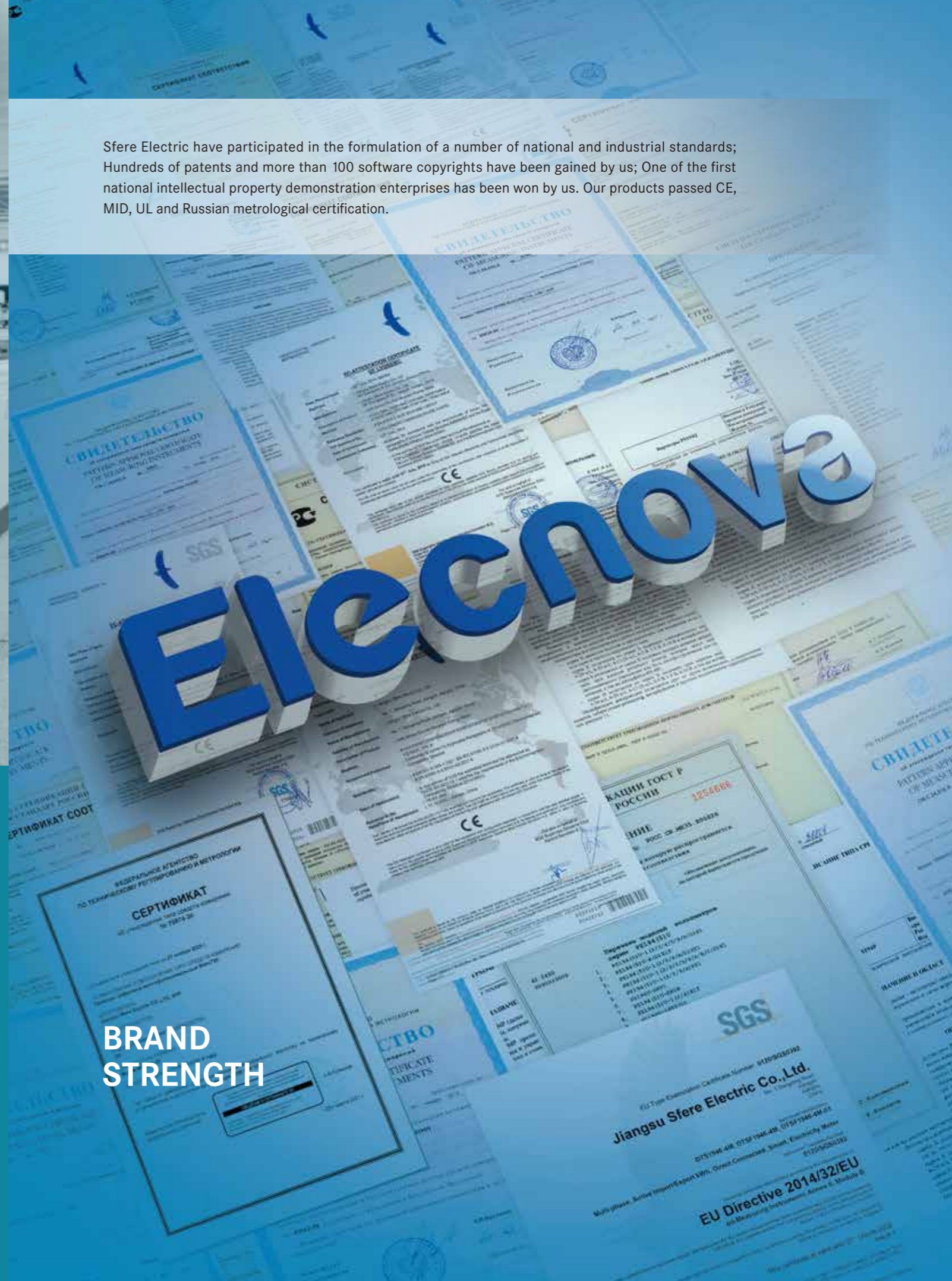

## BRAND STRENGTH

# ЕІЕСПОНА

## MODERN MANAGEMENT

Sfere Electric are in the leading position in establishing ERP, MES and CRM systems in the industry to realize a completely systematic information management. We have developed a highly automatic production line and a capable R&D laboratory, which have made our product technology and quality reached the world advanced level.

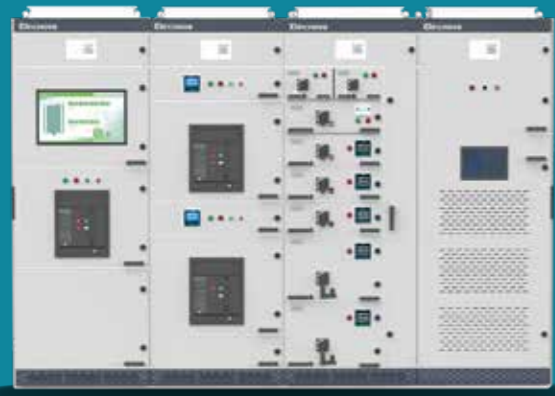

System Platform



Local Server



Cloud Server



Communication Management



Power Monitoring



Power Quality Management



# PRODUCT OVERVIEW

# MULTI-FUNCTIONAL POWER METER

Digital Intelligent Power Distribution Solution Provider

<http://en.sfere-elecnova.com>



FUNCTION



Model		Sfere720	Sfere720B	Sfere720C	Sfere720E
<b>Appearance</b>	Display mode	TFT	LCD	LCD	LED
	Panel mounted	■	■	■	■
<b>Accuracy</b>	Active energy accuracy	0.2S	0.5S	0.2S	0.5S
	Reactive energy accuracy	2	2	2	2
<b>Measurement</b>	V/A/P/Q/S/PF/F	■	■	■	■
	Demand	■	■	■	■
	Max./ Min. value	■	■	■	■
	Neutral current	■	■	■	-
	Fundamental V/A/P/Q/S/PF	■	-	■	-
<b>Energy Metering</b>	Bi-directional energy	■	■	■	■
	Fourquadrant reactive energy	■	■	■	■
	Spare energy	■	■	■	-
	Tariff energy	■	■	■	-
	Fundamental energy	■	-	■	-
<b>Power Quality</b>	THD	■	■	■	■
	Harmonics V/A	2-63rd	2-51st	2-63rd	2-51st
	Sequence component	■	■	■	■
	Unbalance	■	■	■	■
	Crest and K factor	■	■	■	-
	Flicker	■	-	-	-
<b>Data Log</b>	Transient	■	-	-	-
	Hour meter	■	■	■	-
	Demand/ Max./ Min.record	■	■	■	■
	Off-imit record	■	■	■	-
	SOE record	■	■	■	-
	Memory	8MB	-	8MB	-
<b>Input and Output</b>	Energy pulse output	■	■	■	■
	RS485 port (Modbus-RTU)	■	■	■	■
	Digital inputs	2	2	2	-
	Relay outputs	2	2	2	-
<b>Optional Module</b>	FM2 (4 dry digital inputs)	□	-	□	-
	FM3 (2 relay outputs)	□	-	□	-
	FM4 (2 analog inputs)	□	-	□	-
	FM5 (2 temperature inputs)	□	-	□	-
	FM6 (2 analog outputs)	□	-	□	-
	FM7 (Modbus-TCP)	□	-	□	-
	FM8 (Profibus-DP VO)	□	-	□	-
	FM11 (RS485, Modbus-RTU)	□	-	□	-
	FM13 (BACnet/MSTP communication)	□	-	□	-
	FM14 (BACnet/IP communication)	□	-	□	-
	FM17 (DNP3.0)	□	-	□	-
	FM18 (Dual-Ethernet)	□	-	□	-
FM22 (Profinet)	□	-	□	-	

NOTE: "■": Yes "□": No "□": Optional

# Sfere720 Sfere720C



- Memory 8MB
- Energy Accuracy 0.2S
- Harmonics
- Neutral Current Input
- 4 Tariffs
- Optional Modules
- Capacitive Buttons

## FUNCTION

- Networks**
  - TN, TT, IT networks
- Communication**
  - Modbus-RTU
  - Modbus TCP
  - Profibus-DP
- Accuracy**
  - Active energy: 0.2S
  - Voltage: 0.1%
  - Current: 0.1%
- Data Log**
  - Demand record
  - Max./Min.value record
  - Off-limit record
  - SOE record
- Power Quality**
  - THD
  - Harmonics up to 63rd
  - Unbalance
  - Sequence component
  - Crest factor and K factor
  - Waveform display
  - Flicker
  - Transient (Only Sfere720)
- Optional Modules**
  - FM2 (4 dry digital inputs)
  - FM3 (2 relay outputs)
  - FM4 (2 analog inputs)
  - FM5 (2 temperature inputs)
  - FM6 (2 analog outputs)
  - FM7 (Modbus-TCP)
  - FM8 (Profibus-DP)
  - FM11 (RS485, Modbus-RTU)
  - FM13 (BACnet/MSTP communication)
  - FM14 (BACnet/IP communication)
  - FM17 (DNP3.0)
  - FM18 (Dual-Ethernet)
  - FM22 (Profinet)

## APPLICATIONS



## MAIN FEATURES

- Measuring**
  - V/A/P/Q/S/PF/F
  - Demand
  - Max./Min.Value
  - Load profile
- Energy Metering**
  - Bi-directional energy
  - Four-quadrant reactive energy
  - Tariff energy
  - Fundamental energy
- Power Quality**
  - Harmonics up to 63rd
  - Sequence component
  - Unbalance
  - Crest factor and K factor
  - Phasor diagram

Extension Functions				
Modbus-TCP	Modbus-RTU	BACnet/IP	BACnet/MSTP	Profibus-DP
Profinet	Dual-Ethernet	DNP3.0	2 Relay outputs	2 Temperature inputs (PT100)
2 Analog outputs	4 DC digital inputs	2 Analog inputs (4-20mA)		

## DIMENSIONS

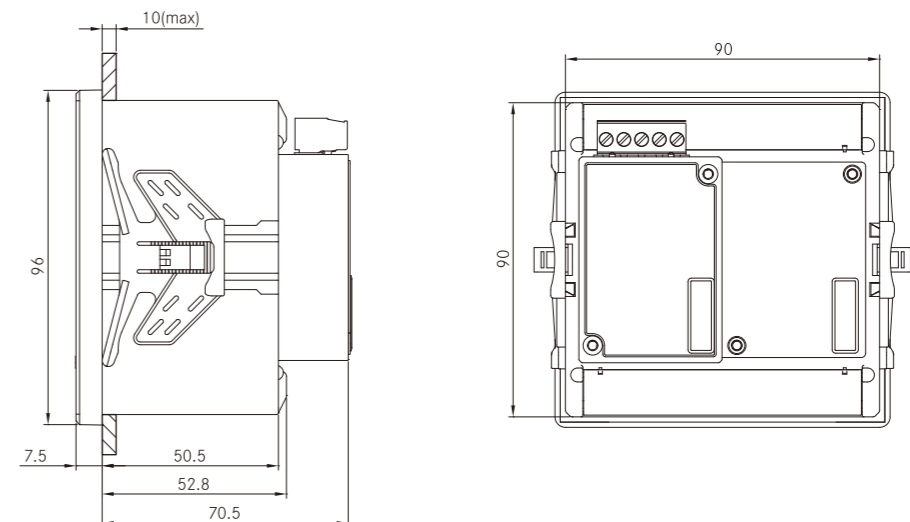

FM3/FM4/FM6/FM11/FM13

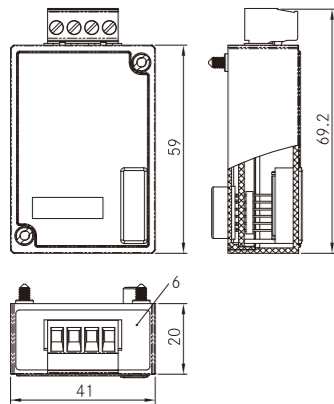

FM2/FM5

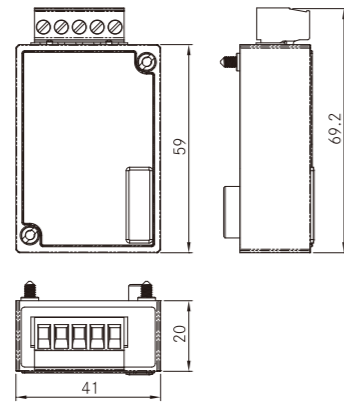

FM8

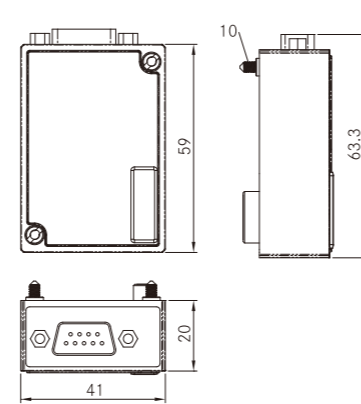

FM7/FM14/FM17

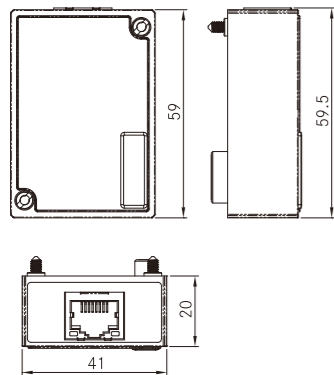

FM18

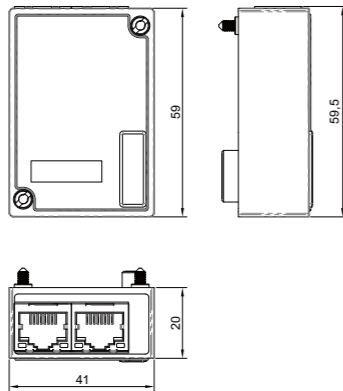

FM22

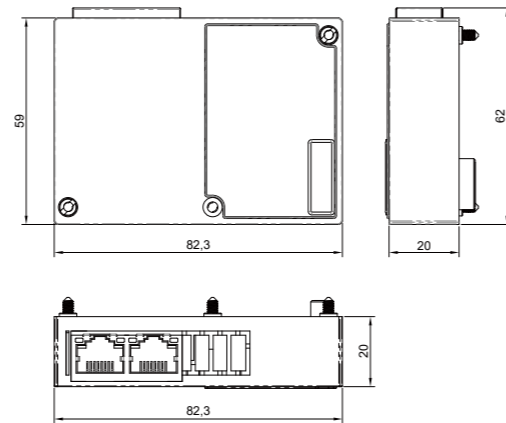

## TYPICAL WIRING

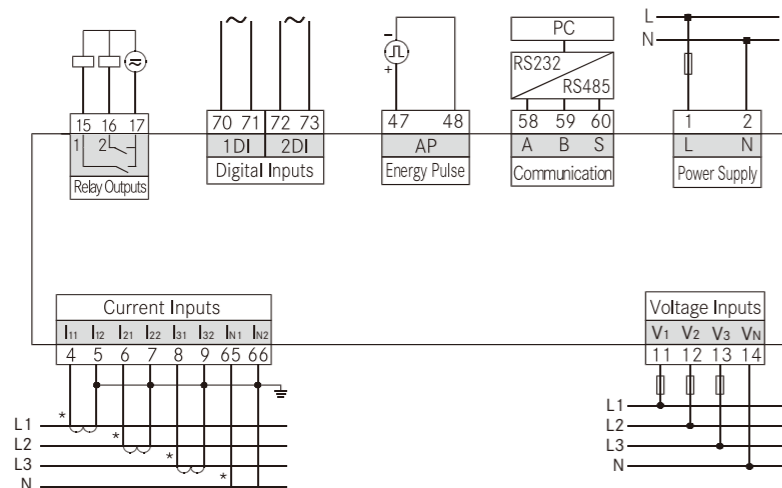

## TECHNICAL SPECIFICATION

<b>Display mode</b>		Sfere720C: LCD, Sfere720: TFT
<b>Accuracy</b>	V/A	0.1%
	P/Q/S/PF	0.2%
	F	±0.01Hz
	±kWh	Class 0.2S
	±kvarh	Class 2
<b>Voltage input</b>	Rated value	AC 3*230/400V 3*100V etc.
	Overload	Continuous: 1.2Vn Instantaneous: 2Vn/10s
	Burden	≤0.1VA (per phase)
	Impedance	4MΩ
	Frequency	45Hz~65 Hz
<b>Current input</b>	Rated value	AC 1A, 5A
	Overload	Continuous: 1.2In Instantaneous: 2In/5s
	Burden	≤0.2VA (per phase)
	Impedance	≤20mΩ
<b>Auxiliary supply</b>	Working range	AC/DC 80~270V 50/60Hz
	Consumption	≤5VA
<b>Communication port</b>		RS485, Modbus-RTU, 2-wire, up to 38.4kbps
<b>Energy pulse output</b>		1 optocoupler output, pulse width (80±20%) ms
<b>Digital input</b>		2 AC 230V inputs, Isolation:5000V AC
<b>Relay output</b>		2 relay outputs, contact rated at AC 5A/250V or DC 5A/30V (AC 1), isolation:2000V AC
<b>Ambient condition</b>	Operating temperature	-25°C - 70°C
	Relative humidity	≤93%
	Altitude	≤2500m
<b>Insulation</b>		≥2kVAC
<b>IP degree</b>		Front IP54, Rear IP20



# Sfere720B



Modbus communication  
 Energy accuracy 0.5S  
 Pulse output  
 Harmonics  
 Neutral current inputs  
 4 tariffs  
 Data record

## FUNCTION

- Networks**
  - TN, TT, IT networks
- Accuracy**
  - Energy: 0.5S
  - Voltage: 0.2%
  - Current: 0.2%
- Communication**
  - Interface:RS485
  - Protocol:Modbus-RTU
- Data Log**
  - Demand record
  - Max./Min. value record
  - Off-limit record
  - SOE record
- Power Quality**
  - THD
  - Harmonics up to 51st
  - Unbalance
  - Sequence component
  - Crest factor and K factor

## APPLICATIONS



## MAIN FEATURES

- Measuring**
  - Demand
  - Max./Min. Value
- Energy Metering**
  - Bi-directional energy
  - 4-quadrant reactive energy
  - Tariff energy
- Power Quality**
  - Harmonics up to 51st
  - Sequence component
  - Unbalance
  - Crest factor and K factor

## DIMENSIONS

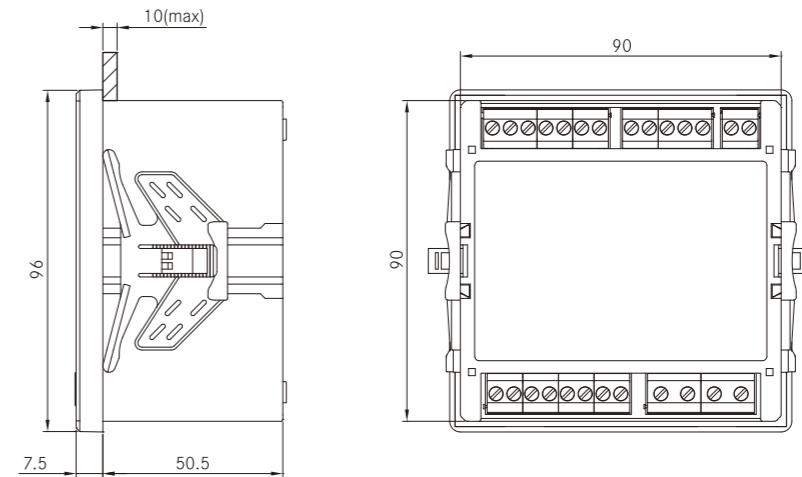

## TYPICAL WIRING

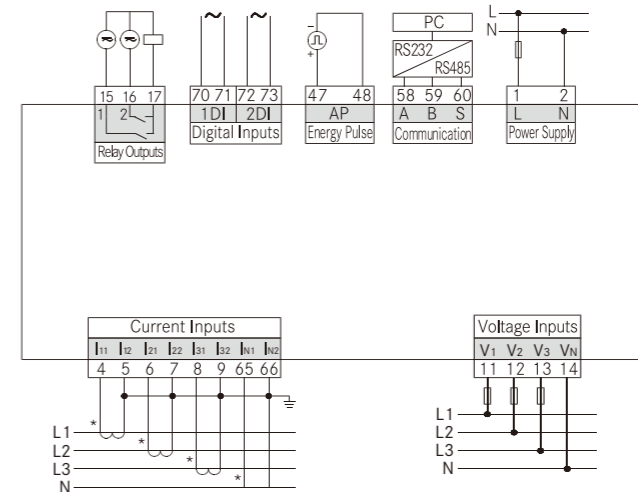

## TECHNICAL SPECIFICATION

<b>Display mode</b>		LCD
<b>Accuracy</b>	V/A	0.2%
	P/Q/S/PF	0.5%
	F	±0.01Hz
	±kWh	Class 0.5S
	±kvarh	Class 2
<b>Voltage input</b>	Rated value	AC 3*230/400V 3*100V etc.
	Overload	Continuous: 1.2Vn Instantaneous: 2Vn/10s
	Burden	≤0.1VA(per phase)
	Impedance	≥1.7MΩ
	Frequency	45Hz~65 Hz
<b>Current input</b>	Rated value	AC 1A, 5A
	Overload	Continuous: 1.2Vn Instantaneous: 2In/5s
	Burden	≤0.2VA(per phase)
	Impedance	≤20mΩ
<b>Power supply</b>	Working range	AC/DC 80~270V 50/60Hz
	Consumption	≤5VA
<b>Communication</b>		RS485, Modbus-RTU, 2-wire, up to 38400bps
<b>Energy pulse output</b>		1 optocoupler output, pulse width (80±20%) ms
<b>Digital input</b>		2 AC 230V inputs, Isolation:5000V AC
<b>Relay output</b>		2 relay outputs, contact rated at AC 5A/250V or DC 5A/30V (AC 1), isolation:2000V AC
<b>Ambient condition</b>	Operating temperature	-25~70°C
	Relative humidity	≤93%
	Altitude	≤2500m
<b>Insulation</b>		≥ AC 2kV
<b>IP degree</b>		Front IP54, Rear IP20

## Sfere720E



Ultra-thin Design  
Bracket Free Installation



## FUNCTION

- Networks**  
 -TN, TT, IT networks
- Accuracy**  
 -Energy: 0.5S  
 -Voltage: 0.2%  
 -Current: 0.2%
- Communication**  
 -Interface: RS485  
 -Protocol: Modbus-RTU
- Power Quality**  
 -THD  
 -Harmonics up to 51st  
 -Unbalance

## APPLICATIONS

Data Acquisition

Energy Management

Remote Power Monitoring

## DIMENSIONS

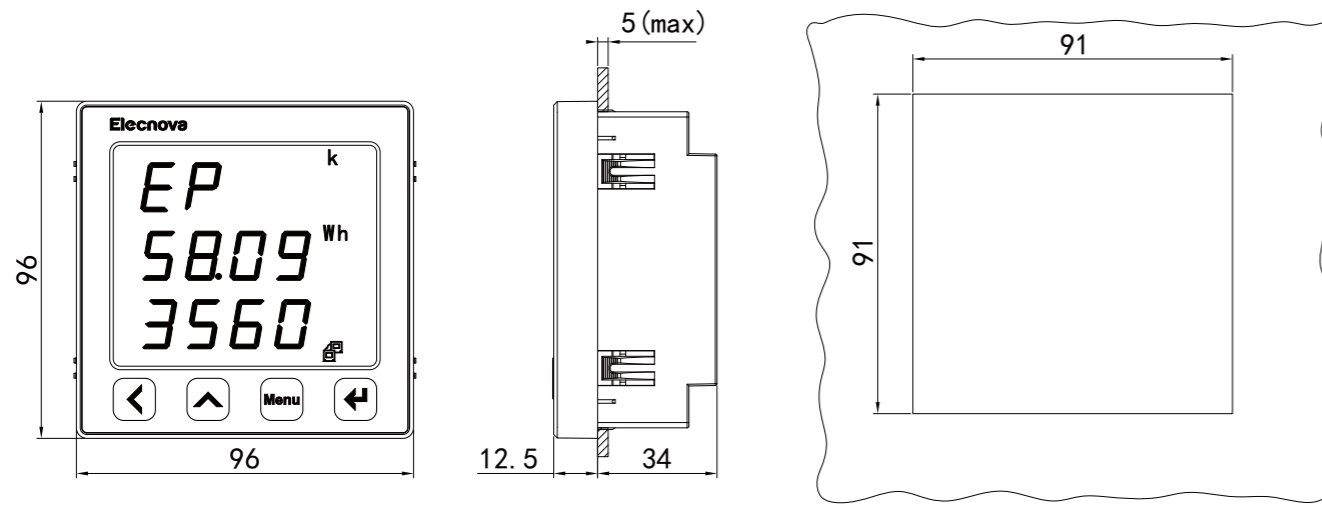

## TYPICAL WIRING

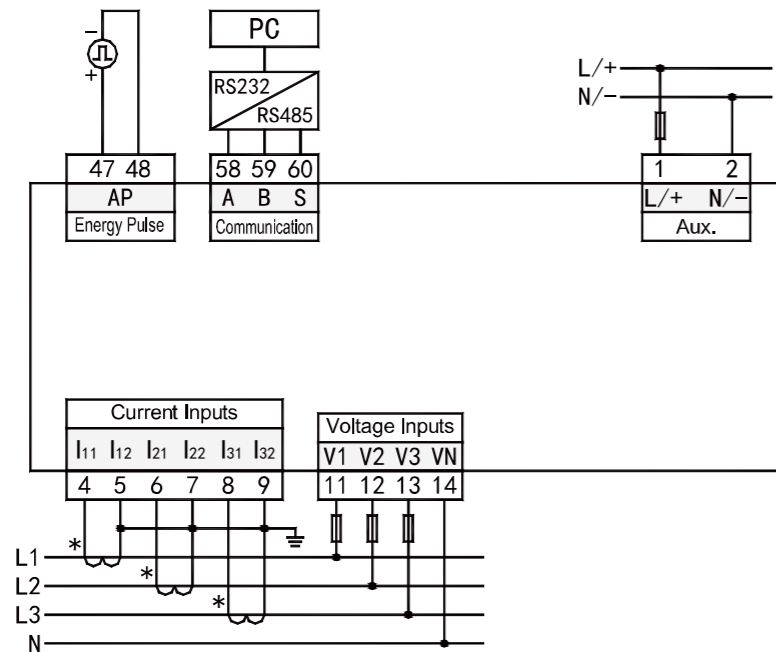

## TECHNICAL SPECIFICATION

<b>Display</b>		LED
<b>Accuracy</b>	V/A	0.2%
	P/Q/S/PF	0.5%
	F	±0.01Hz
	±kWh	Class 0.5S
	±kvarh	Class 2
<b>Working power supply</b>	Rated range	AC/DC 80~270V 50/60Hz
	Power consumption	≤ 5VA
	Withstand voltage	≥ 2kV
<b>Voltage input</b>	Range	AC 3*230/400V 3*100V etc.
	Resolution	0.1 V
	Impedance	≥ 1.7 MΩ / per phase
	Power consumption	≤ 0.1 VA / per phase
	Overload	Continuous: 1.2Vn Instantaneous: 2Vn/1min
	Frequency	45-65 Hz
	<b>Current input</b>	Range
Resolution		1 mA
Impedance		≤ 20mΩ / per phase
Power consumption		≤ 0.2 VA / per phase
Overload		Continuous: 1.2Vn Instantaneous: 10In/5s
<b>Energy pulse output</b>		Pulse width
	Max. terminal voltage	35V
	Max. terminal current	10mA
	Pulse frequency	≤ 10Hz
	Output object	Import active energy, import reactive energy
<b>Communication interface</b>	Physical interface	RS-485
	Communication speed	Up to 9600bps
	Communication protocol	Modbus-RTU
	Isolation voltage	2000V AC (1 min)
<b>Ambient condition</b>	Working temperature	-40°C ~ 70°C
	Relative humidity	≤ 95% RH, no condensation
	Working altitude	≤ 2500m
	Anti-pollution level	Non-corrosive gas
	Protection degree	Front case IP54, rear case IP20
	Insulation	≥ 2kV AC

# PD194Z-9HY



Energy accuracy 0.5S  
Pulse output  
Harmonics



## FUNCTION

- Networks**
  - TN, TT, IT networks
- Accuracy**
  - Energy: 0.5S
  - Voltage: 0.2%
  - Current: 0.2%
- Communication**
  - Interface: RS485
  - Protocol: Modbus-RTU

## MAIN FEATURES

- Measuring**
  - Fundamental V/A
  - Demand
  - Max./Min. Value
- Energy Metering**
  - Bi-directional energy
  - 4-quadrant reactive energy
  - Tariff energy
- Power Quality**
  - Harmonics up to 51st
  - Unbalance

## APPLICATIONS

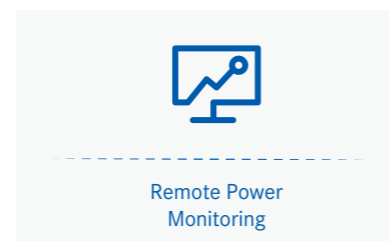
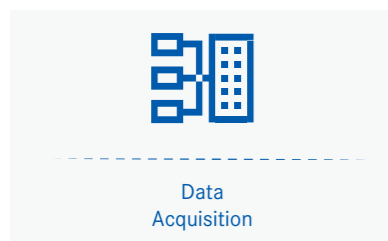

## MODEL

Function	PD194Z-9HY	PD194Z-9HYE	PD194Z-9HYTR
<b>Display method</b>	3.8" LCD	■	
<b>Real-time measurement</b>	U, I, P, Q, S, PF, Hz	■	
	Demand	■	
	Max, Min, Average value	■	
	Residual current	-	1
	Temperature	-	6
<b>Energy metering</b>	Bi-directional active energy	■	
	Bi-directional reactive energy	■	
	Four-quadrant reactive energy	■	
	Tariff energy (6 sets)	■	
<b>Power quality monitoring</b>	THDi, THDu	■	
	Individual harmonic ratio		2-51st
	Unbalance	■	
	Voltage crest factor	■	
	Current K factor	■	
<b>Communication</b>	RS485		1
	Ethernet	-	1
<b>Input/output</b>	Digital input		6
	Relay output	3	2
	Analog output	1	-
	Energy pulse output		1
<b>Other</b>	Event records	■	
	Freezing data	■	
	Communication register address mapping	■	

NOTE: "■": Yes "-": No

## DIMENSIONS

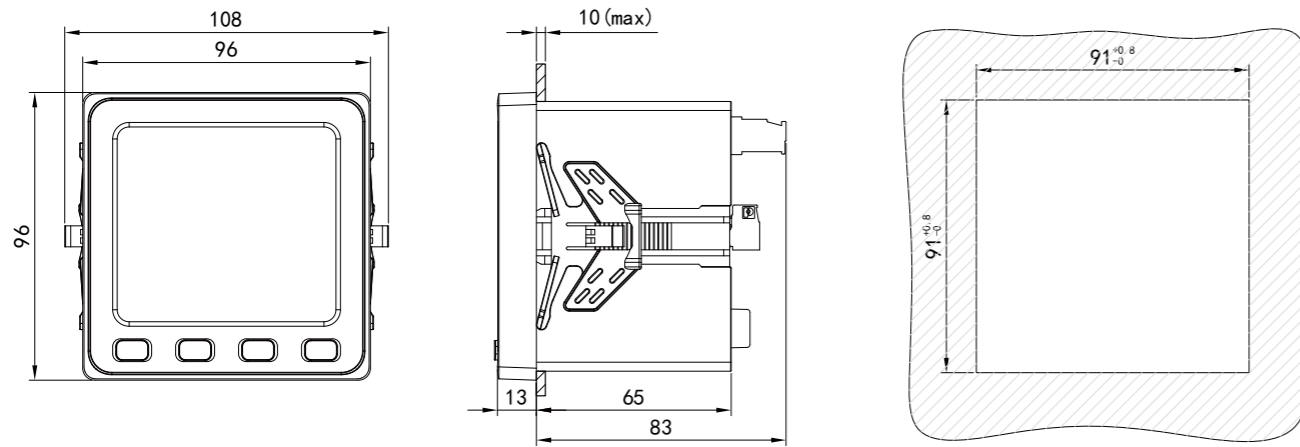

## TYPICAL WIRING

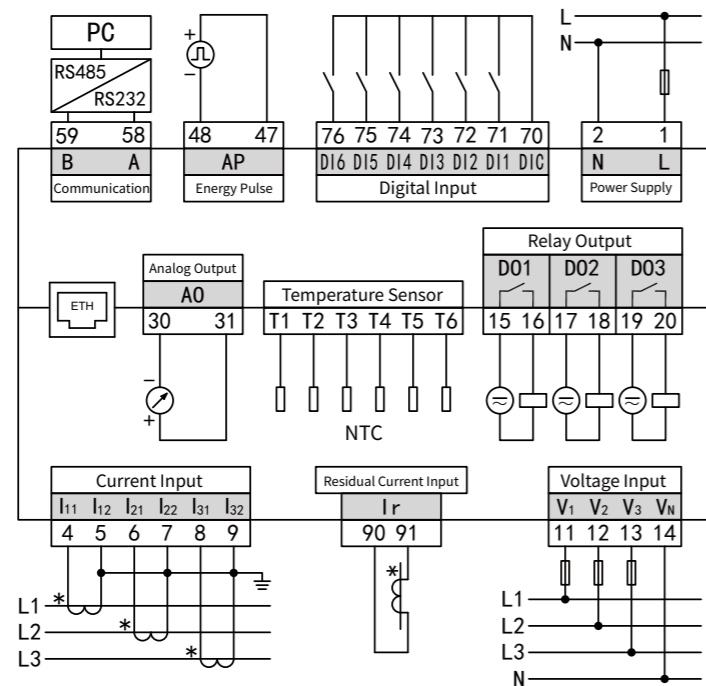

## TECHNICAL SPECIFICATION

<b>Voltage input</b>	Rated value	AC 3*230/400V 3*100V etc.
	Impedance	$\geq 1.7 \text{ M}\Omega$ /phase
	Power consumption	$\leq 0.1 \text{ VA}$ /phase
	Overload	Continuous: $1.2V_n$ , Instantaneous: $2V_n/1\text{min}$
	Frequency	45Hz-65Hz
<b>Current input</b>	Rated value	1A or 5A
	Startup value	10mA
	Resolution	1mA
	Impedance	$\leq 20 \text{ m}\Omega$ /phase
	Power consumption	$\leq 0.2 \text{ VA}$ /phase
<b>Ambient condition</b>	Overload	Continuous: $2I_n$ , Instantaneous: $20I_n/1\text{s}$
	Operating temperature	$-25^\circ\text{C} - +70^\circ\text{C}$
	Relative humidity	5%-95%RH, No condensation
	Working altitude	$\leq 2000\text{m}$
	Pollution degree	2
<b>Mechanical features</b>	Dimension	96mm×96mm×83mm
	IP	Front IP54, Back IP20
<b>Security features</b>	Measurement category	300V CAT III
	Safety	IEC 61010-1, Double insulation
<b>Analog output</b>	Number	1
	Type	4-20mA, 4-12-20mA
	Load capacity	$\leq 350 \Omega$
<b>Relay output</b>	Number	3 (MAX)
	Contact rating	AC 250V/5A or DC30V/5A (AC1)
<b>Digital input</b>	Number	6
	Type	Dry contact, built-in DC 24V
<b>Temperature measurement</b>	Number	6
	Range	$-20^\circ\text{C} \sim 140^\circ\text{C}$
	Accuracy	$\pm 2^\circ\text{C}$
<b>Residual current</b>	Number	1
	Rated Value	AC 1000mA/0.5mA
<b>Auxiliary power</b>	Voltage	AC/DC 80~270V 50/60Hz
	Power consumption	$\leq 5\text{VA}$
	Communication interface	RS485 Port Ethernet Modbus-TCP Optional
<b>Real time clock</b>	Clock drift	$\leq 0.5\text{s/day}$
	Standard	IEC 61557-12, IEC62053-22, IEC62053-23, IEC 61010-1, IEC 61326-1

# PD194Z-9TY



Dot-matrix LCD  
Energy accuracy 0.5S  
Modbus Interface  
Harmonics



## FUNCTION

- Networks**
  - TN, TT, IT networks
- Accuracy**
  - Energy: 0.5S
  - Voltage: 0.2%
  - Current: 0.2%
- Communication**
  - Interface: RS485
  - Protocol: Modbus-RTU

## MAIN FEATURES

- Measuring**
  - Demand
  - Max./Min. Value
- Energy Metering**
  - Bi-directionAL energy
  - 4-quadrant reactive energy
  - Tariff energy (Optional)
- Power Quality**
  - Harmonics up to 31st
  - Sequence component
  - Unbalance
  - Crest factor and K factor

## APPLICATIONS



Data Acquisition



Energy Management



Remote Power Monitoring

## MODEL

Model	PD194Z-9TY	
<b>Appearance</b>	Display mode	Dot-matrix LCD
	Panel mounted	■
<b>Accuracy</b>	Active energy accuracy	0.5S
	Reactive energy accuracy	2
<b>Measuring</b>	V/A/P/Q/S/PF/F	■
	Demand	■
	Max. / Min. value	■
	Fundamental V/A	■
<b>Energy metering</b>	Bi-directional energy	■
	4-quadrant reactive energy	■
	Tariff energy	□
<b>Power quality</b>	THDu, THDi	■
	Harmonics content	2-31st
	Sequence component	■
	Unbalance	■
	Crest & K factor	■
<b>Data log</b>	Demand/Max./Min. record	■
	Off-limit record	■
<b>I/O</b>	Energy pulse output	2
	RS485 port (Modbus-RTU)	1
	Relay output	3
	Digital input	4
	Analog output	1
<b>Other</b>	Meter & Load running time	■

NOTE: "■": Yes "—" No "□": Optional

## DIMENSIONS

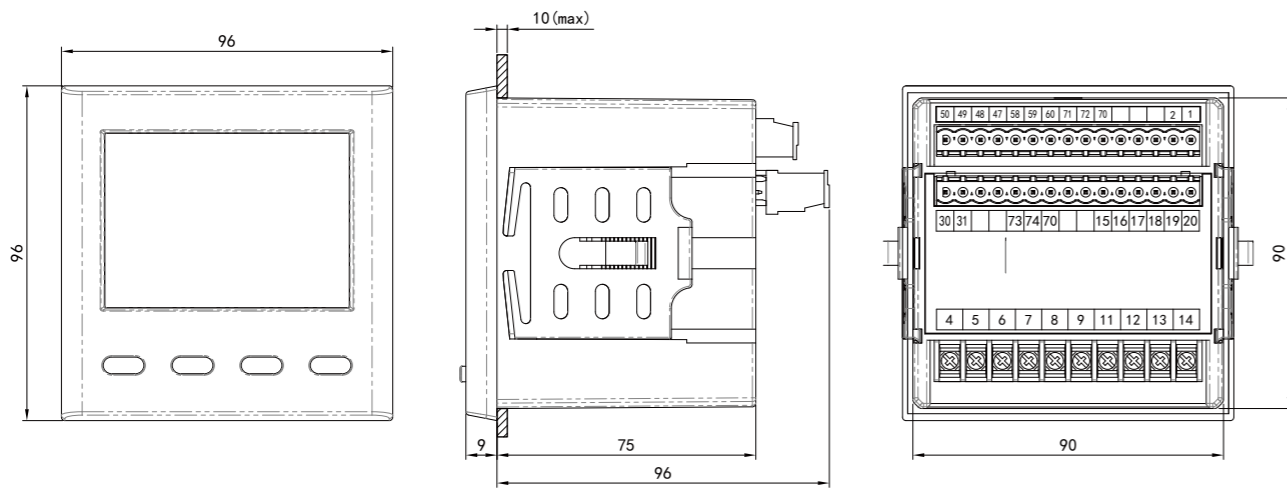

## TYPICAL WIRING

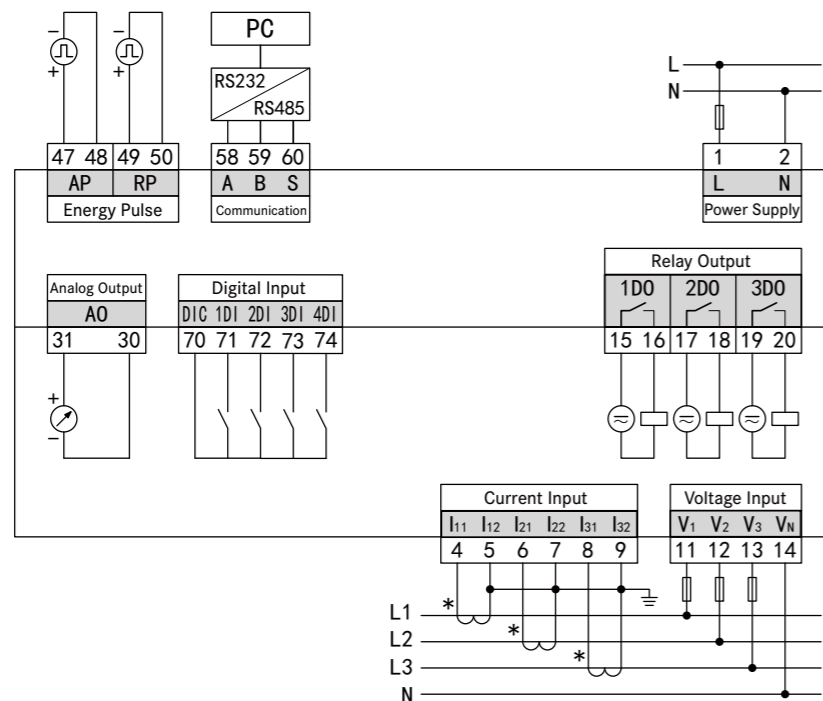

## TECHNICAL SPECIFICATION

Item	Parameters		
Accuracy	Voltage and current:0.2%	Power, Reactive power, Power Factor:0.5%	
	Harmonics: Class A	Active energy: class 0.5S	
	Reactive energy: class 2	Analog output: class 0.5	
Display mode	LCD display		
Signal input	Wiring mode	3P3W, 3P4W	
	Voltage	Rated value	AC 3*230/400V 3*100V etc.
		Overload	Continuous: 1.2In, Instantaneous: 2Vin/10s
		burden	≤0.1VA (each phase)
	Current	Rated value	AC 1A, 5A
		Overload	Continuous: 1.2In, Instantaneous: 10In/5s
		burden	≤0.1VA (each phase)
	Rated value	≤20mΩ	
	Power supply	Grid frequency	45-65 Hz, Accuracy: ±0.01Hz
		Working range	AC/DC 80~270V 50/60Hz
consumption		≤5VA	
I/O	Energy pulse output	2 energy pulse outputs, optocoupler isolation	
	Communication port	1 RS-485 communication, Modbus-RTU protocol, Baud rate: 1200~19200bps	
	Digital input	4 digital input at most, dry contact mode	
	Digital output	3 relay outputs at most, AC250V/5A, DC30V/5A (AC1)	
	Analog output	1 analog output, 0/4~20mA or 4~12~20mA	
Ambient condition	-25~70°C, ≤93%RH, Non corrosive gas site, altitude≤2500m		
Safety	Insulation	Signal, power supply, output terminals to case resistance >100MΩ	
	Withstand voltage	Power supply, input and output >2kV	

# LNF Series

## Multi-function Meter



Real-time measurement  
Switch status monitoring  
Power quality monitoring  
Limit alarm  
Energy metering



### FUNCTION

#### Networks

-TN, TT, IT networks

#### Communication

-Interface:RS485  
-Protocol:Modbus-RTU

#### Accuracy

-U, I, Class 0.2  
-P, Q, PF Class 0.5  
-kWh Class 0.5S

### MAIN FEATURES

#### Measuring

-Demand  
-Max./Min. Value

#### Energy metering

-Bi-directional energy  
-4-quadrant reactive energy  
-Tariff energy (Optional)

#### Power quality

-Harmonics up to 31st  
-Sequence component  
-Unbalance  
-Crest factor and K factor

### APPLICATIONS

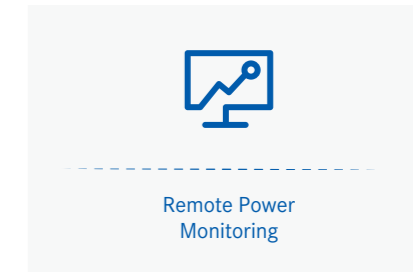
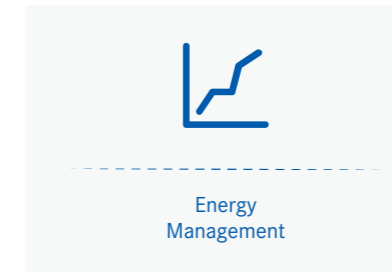

### DIMENSIONS

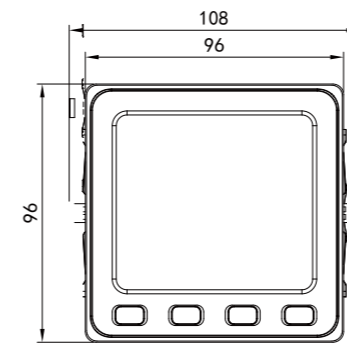

LNF96 Series

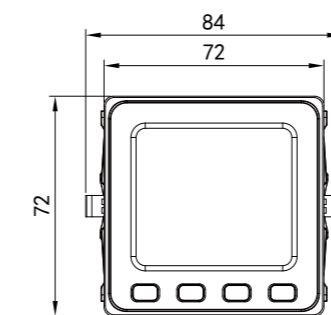
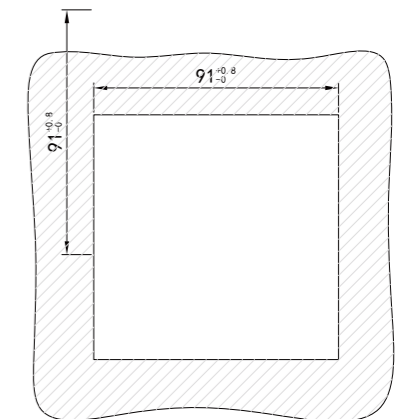
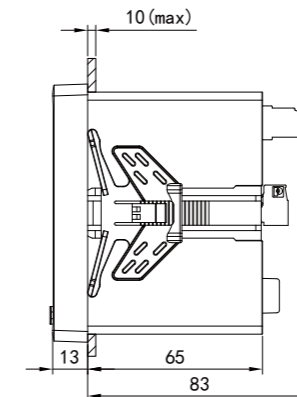

LNF72 Series

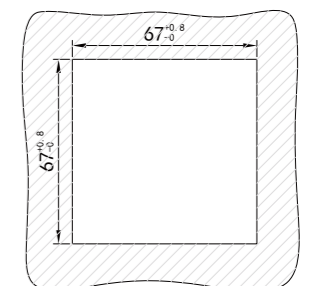
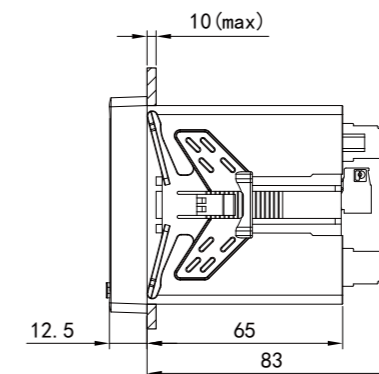





Function		LNF72EY-C	LNF72EY-CJK	LNF72EY-CMJKF	LNF72E-C	LNF72E-CJK	LNF72E-CMJK
		LNF96EY-C	LNF96EY-CJK	LNF96EY-CMJKF	LNF96E-C	LNF96E-CJK	LNF96E-CMJK
<b>Display method</b>	Display	LCD	LCD	LCD	LED	LED	LED
<b>Real-time measurement</b>	U, I, P, Q, S, PF, Hz	■	■	■	■	■	■
	Demand	■	■	■	■	■	■
	Max, Min, Average value	■	■	■	■	■	■
<b>Energy metering</b>	Bi-directional active energy	■	■	■	■	■	■
	Bi-directional reactive energy	■	■	■	■	■	■
	Four-quadrant reactive energy	■	■	■	■	■	■
	Tariff energy (6 sets)	-	-	■	-	-	-
<b>Power quality monitoring</b>	THDi, THDu	■	■	■	■	■	■
	Individual harmonic ratio	2-31st	2-31st	2-31st	2-31st	2-31st	2-31st
	Unbalance	■	■	■	■	■	■
<b>Communication</b>	RS485	1	1	1	1	1	1
<b>Input/output</b>	Digital input	-	4	4	-	4	4
	Relay output	-	2	2	-	2	2
	Analog output	-	-	1	-	-	1
	Energy pulse output (LNF96 Series)	1	1	1	1	1	1
<b>Others</b>	Limit alarm	■	■	■	■	■	■
	Event records	-	-	■	-	-	■
	Freezing data	-	-	■	-	-	■
	Communication register address mapping	■	■	■	■	■	■

NOTE: ■: Yes -: No

## TECHNICAL SPECIFICATION

<b>Voltage input</b>	Rated value	AC 3*230/400V 3*100V etc.
	Startup value	10V
	Resolution	0.1 V
	Impedance	$\geq 1.7 \text{ M}\Omega/\text{phase}$
	Power consumption	$\leq 0.1 \text{ VA /phase}$
	Overload	Continued: 1.2Vn, Instantaneous: 2Vn/1min
	Frequency	45Hz-65Hz
<b>Current input</b>	Rated value	AC 1A, 5A
	Startup value	10mA
	Resolution	1mA
	Impedance	$\leq 20\text{m}\Omega/\text{phase}$
	Power consumption	$\leq 0.2 \text{ VA/phase}$
	Overload	Continued: 2In, Instantaneous: 20In/1s
	<b>Ambient condition</b>	Operating temperature
Relative humidity		5%-95%RH, No condensation
Working altitude		$\leq 2000\text{m}$
Pollution degree		2
<b>Mechanical features</b>		Dimension
	IP	Front IP54, Back IP20
<b>Security features</b>	Measurement category	300V CAT III
	Safety	IEC 61010-1, Double insulation
<b>Analog output</b>	Number	1
	Type	4-20mA, 4-12-20mA
	Load capacity	$\leq 350\Omega$
<b>Relay output</b>	Number	2
	Contact rating	AC 250V/5A or DC30V/5A (AC1)

<b>Digital input</b>	Number	4
	Type	Dry contact, built-in DC 24V
<b>Auxiliary power</b>	Voltage	AC/DC 80~270V 50/60Hz
	Power consumption	$\leq 5\text{VA}$
<b>Communication interface</b>	RS485	Modbus-RTU
<b>Real time clock</b>	Clock drift	$\leq 0.5\text{s/day}$
<b>Standard</b>	IEC 61557-12, IEC62053-22, IEC62053-23, IEC 61010-1, IEC 61326-1	

## TYPICAL WIRING

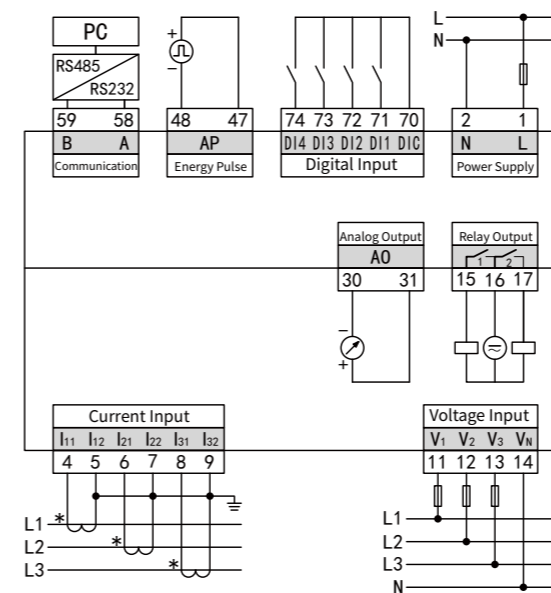

LNF96E/EY-CMJK

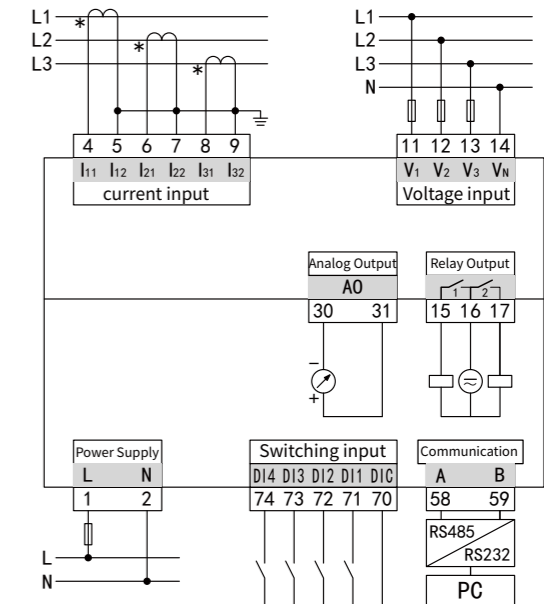

LNF72E/EY-CMJK

# PD194Z-E200



Energy accuracy 0.5S  
Pulse output  
Harmonics



## FUNCTION

### Networks

-TN, TT, IT networks

### Accuracy

-Energy: 0.5S  
-Voltage: 0.2%  
-Current: 0.2%

### Communication

-Interface: RS485  
-Protocol: Modbus-RTU

## MAIN FEATURES

### Measuring

-Fundamental V/A  
-Demand  
-Max./Min. Value  
-Load profile

### Energy Metering

-Bi-direction energy  
-4 quadrants reactive energy  
-Tariff energy

### Power Quality

-Harmonics up to 51st  
-Unbalance

## APPLICATIONS



Data Acquisition



Energy Management



Remote Power Monitoring

## MODEL

Function	PD194Z-E200-CJK	PD194Z-E200-CJKTR
Display method	LCD	■
Real-time measurement	U, I, P, Q, S, PF, Hz	■
	Demand	■
	Max, Min, Average value	■
	Residual current	- 1
	Temperature	- 4
Energy metering	Bi-directional active energy	■
	Bi-directional reactive energy	■
	Four-quadrant reactive energy	■
	Tariff energy (6 sets)	■
Power quality monitoring	THDi, THDu	■
	Individual harmonic ratio	2-51st
	Unbalance	■
	Voltage crest factor	■
	Current K factor	■
Communication	RS485	1
Input/output	Digital input	4
	Relay output	2
	Energy pulse output	1
Other	Event records	■
	Freezing data	■
	Communication register address mapping	■

NOTE: "■": Yes " - ": No

## DIMENSIONS

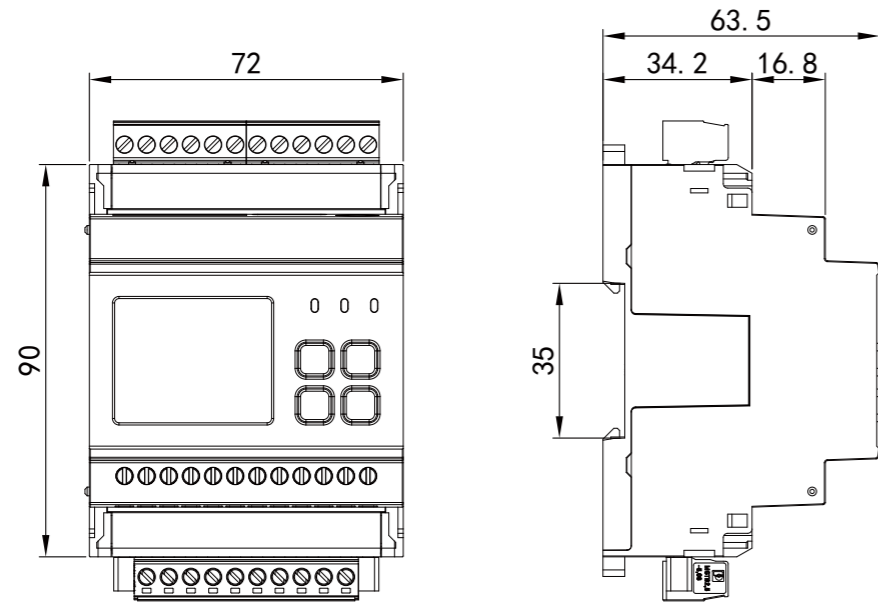

## TYPICAL WIRING

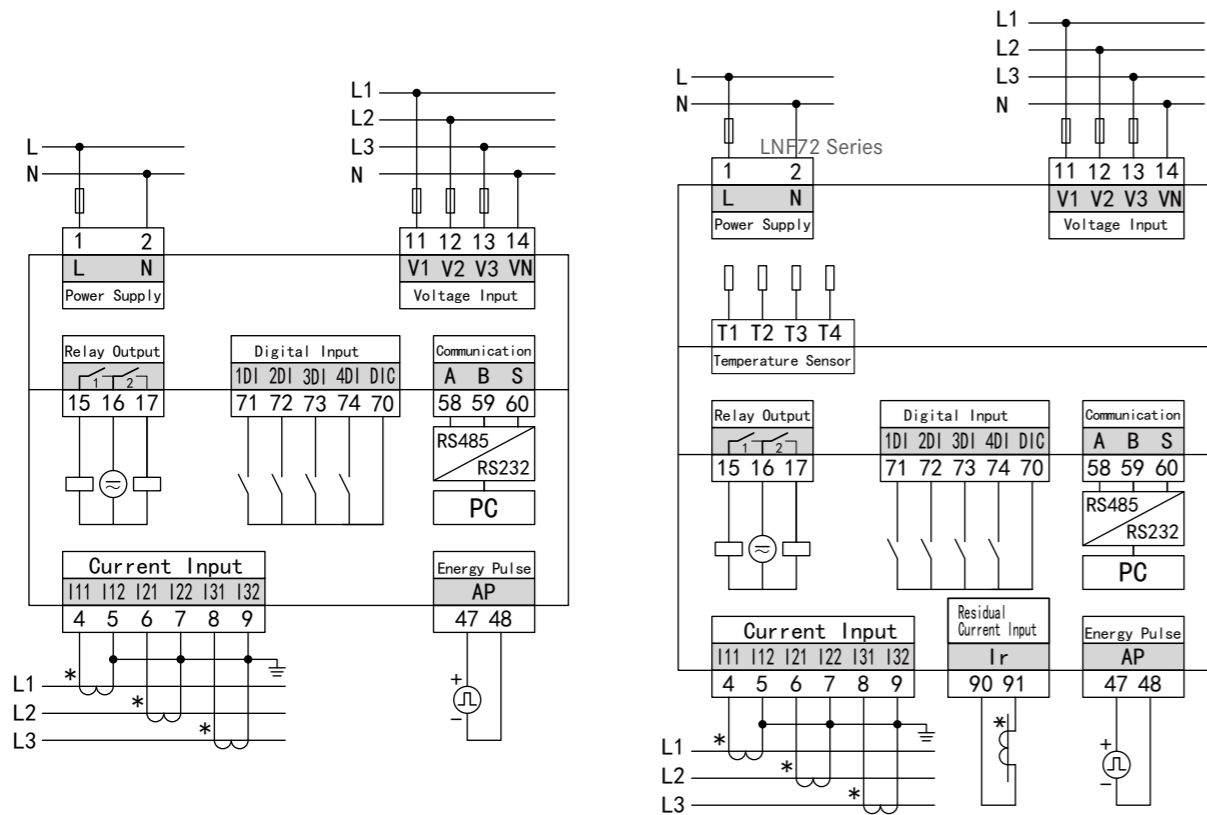

PD194Z-E200-CJK

PD194Z-E200-CJKTR

## TECHNICAL SPECIFICATION

<b>Voltage input</b>	Rated value	AC 3*230/400V 3*100V etc.
	Impedance	$\geq 1.7 \text{ M}\Omega$ /phase
	Power consumption	$\leq 0.1 \text{ VA}$ /phase
	Overload	Continuous: 1.2Vn, Instantaneous: 2Vn/1min
	Frequency	45Hz-65Hz
<b>Current input</b>	Rated value	1A or 5A
	Startup value	10mA
	Resolution	1mA
	Impedance	$\leq 20 \text{ m}\Omega$ /phase
	Power consumption	$\leq 0.2 \text{ VA}$ /phase
<b>Ambient condition</b>	Overload	Continuous: 2In, Instantaneous: 20In/1s
	Operating temperature	-25°C - +70°C
	Relative humidity	5%-95%RH, No condensation
	Working altitude	$\leq 2000 \text{ m}$
	Pollution degree	2
<b>Security features</b>	IP	IP20
	Measurement category	300V CAT III
<b>Relay output</b>	Safety	IEC 61010-1, Double insulation
	Number	2
<b>Digital input</b>	Contact rating	AC 250V/5A or DC30V/5A (AC1)
	Number	4
<b>Temperature measurement</b>	Type	Dry contact, built-in DC 24V
	Number	4
	Range	-20°C ~ 140°C
<b>Residual current</b>	Accuracy	$\pm 2^\circ \text{C}$
	Number	1
<b>Auxiliary power</b>	Rated Value	AC 1000mA/0.5mA
	Voltage	AC/DC 80~270V 50/60Hz
<b>Communication interface</b>	Power consumption	$\leq 5 \text{ VA}$
	RS485 Port	Modbus-RTU, up to 38400bps
<b>Real time clock</b>	Ethernet Modbus-TCP	Optional
	Clock drift	$\leq 0.5 \text{ s/day}$
<b>Standard</b>	IEC 61557-12, IEC62053-22, IEC62053-23, IEC 61010-1, IEC 61326-1	

# DIN RAIL MOUNTED ENERGY METER

Digital Intelligent Power Distribution Solution Provider  
<http://en.sfere-elecnova.com>



## S36

### Multi-users Prepaid Energy Meter



All-parameter measurement & Energy metering  
 Time-sharing billing & Prepayment  
 Demand statistics & Event record  
 Malignant load identification & Fault alarm

#### APPLICATIONS

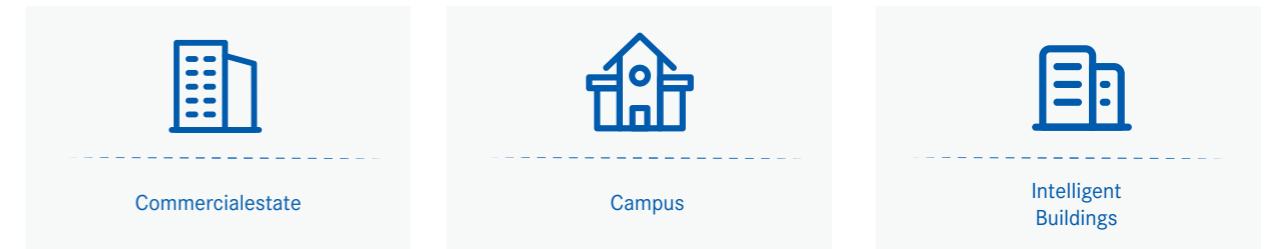

#### DIMENSIONS

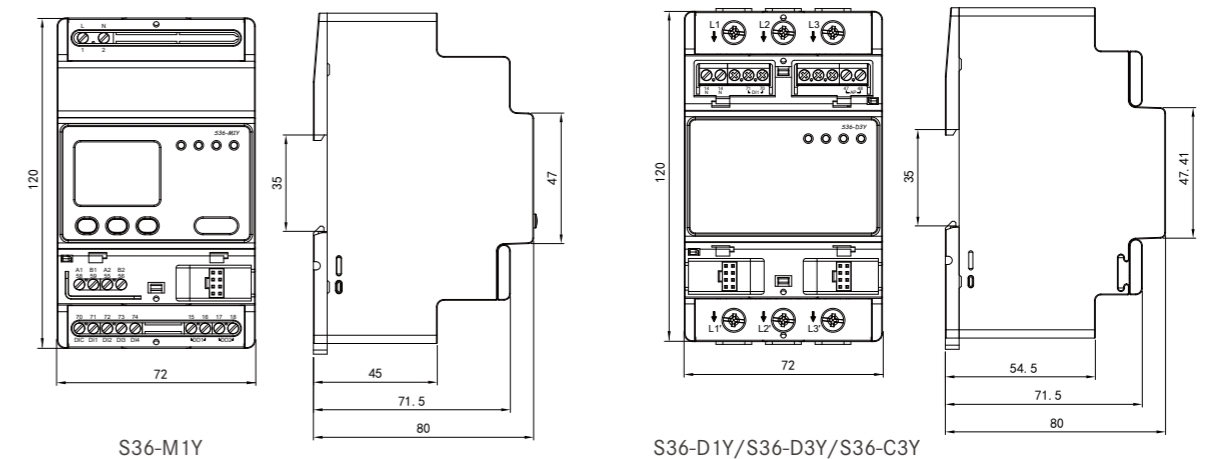

## TYPICAL WIRING

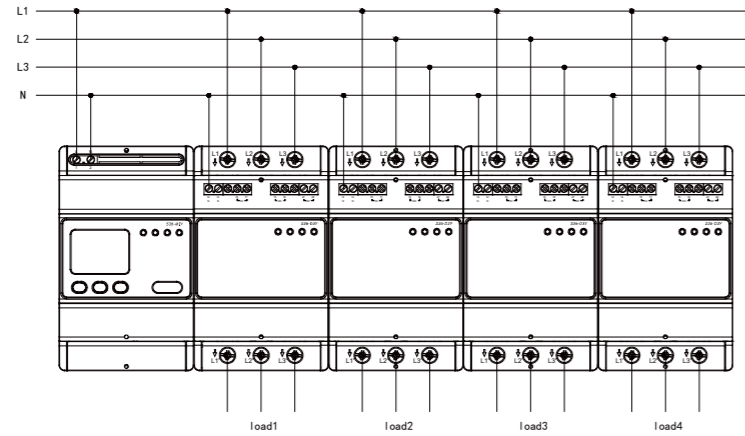

S36 three-phase direct connection wiring diagram

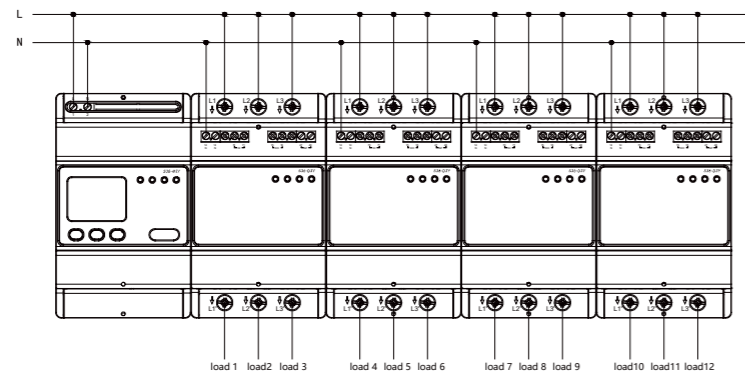

S36 single-phase direct connection wiring diagram

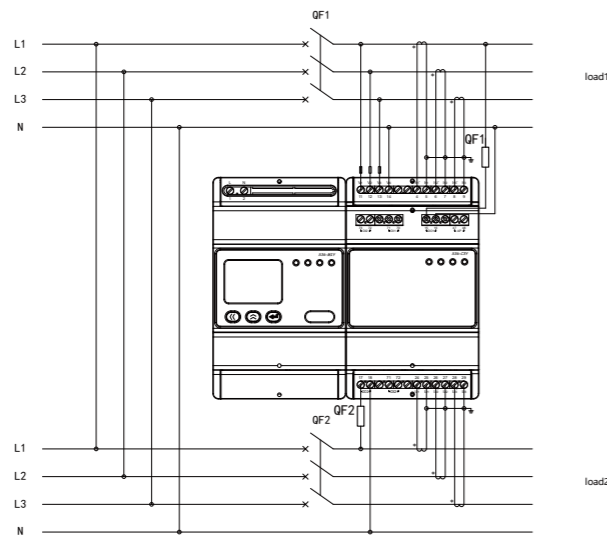

S36 three-phase connection via CT wiring diagram

## MODEL

Main module		S36-M1Y		
I/O	Digital input	4 channels		
	Relay output	2 channels		
Communication	RS485 interface	2 channels		
	Ethernet interface	■		
Management function	Information query	■		
	Parameter configuration	■		
	Local switch on/off control	■		
Display mode	Dot matrix LCD, support multi-language option	■		
Measurement module		S36-D1Y	S36-D3Y	S36-C3Y
Wiring mode	Single-phase, direct	3	-	-
	Three-phase, direct	-	1	-
	Three-phase, via CT	-	-	2
Rated voltage	230V	■	-	-
	3×230/400V	-	■	■
Current		80A	80A	6A
Real-time measurement	U, I, P, Q, PF, Hz	■	■	■
Energy metering	Bi-directional energy	■	■	■
	Tariff energy	■	■	■
Freezing function	Instantaneous/agreed freezing	■	■	■
	Parameter/energy timing freezing	■	■	■
	Energy daily/monthly freezing	■	■	■
Management	Prepayment management	■	■	■
	Step tariff	■	■	■
	Malignant load identification	■	-	-
	Power-maintain in holiday	■	■	■
	Event record	■	■	■
I/O	Digital input	1 channel	1 channel	2 channel
	Relay output	3 channels	3 channels	4 channels

NOTE: "■": Yes " - ": No

Main module S36-M1Y	
Working voltage	AC 3*230/400V
I/O characteristic	
Digital input	Dry contact, built-in 24V power supply, Input resistance: conduction<10k Ω, disconnection >15k Ω
Relay output	Contact capacity: 5A/250 VAC; 5A/30 VDC
Communication characteristic	
RS485 interface	Modbus-RTU protocol, baud rate up to 38400bps
Ethernet interface	Modbus-TCP protocol
Mechanical characteristic	
Dimension	72×120×80mm
Protection degree	IP54 (Front case)
Ambient condition	
Working temperature	-25°C - +70°C
Relative humidity	5%-95%RH, No condensation

Measuring module S36-C3Y		
Accuracy	U, I: 0.2%; P: 0.5%; Hz:±0.01Hz; Active energy: 0.5S, Reactive energy: Class 2	
Rated Voltage	Three-phase	AC 3*230/400V
Input current	Via CT	AC 3×1.5(6)A
Frequency		50/60 Hz
Wiring mode		3P4W
Consumption	Voltage circuit	< 0.2VA
	Current circuit	< 0.2VA
Start-up current	Access via CT	0.002lb
I/O characteristic		
Digital input	AC wet contact, ON: AC 180...270V, OFF: < AC 100V	
Relay output	AC 250V/5A or DC 30V/5A (AC 1)	
Energy pulse	Pulse width 80ms±20ms	
Mechanical characteristic		
Dimension	72×120×80mm	
Protection degree	IP54 (Front case)	
Ambient condition		
Working temperature	-25°C - +70°C	
Relative humidity	5%-95%RH, No condensation	

## TECHNICAL SPECIFICATION

Measuring module S36-D1Y /S36-D3Y		
Accuracy		U, I: 0.2%; P: 0.5%; Hz:±0.01Hz; Active energy: Class 0.5S, Reactive energy: Class 2
Rated voltage	Three-phase	AC 3*230/400V
	Single-phase	AC 230V
Input current	Direct	AC 0.1-0.5(80)A
Frequency		50/60 Hz
Wiring mode		S36-D1Y: single-phase S36-D3Y: 3P4W
Consumption	Voltage circuit	< 1VA
	Current circuit	< 1VA
Start-up current	Access via CT	0.004Ib
I/O characteristic		
Digital input		AC wet contact, ON: AC 180...270V, OFF: < AC 100V
Relay output		Contact capacity: 90A/250V AC
Energy pulse		Pulse width 80ms±20ms
Mechanical characteristic		
Dimension		72×120×80mm
Protection degree		IP54 (Front case)
Ambient condition		
Working temperature		-25°C - +70°C
Relative humidity		5%-95%RH, No condensation

# DDS/DSS/DTS1946 Series



Modbus Interface  
Programmable  
DIN Rail Mounted



## MAIN FEATURES

- Measuring**  
 -Direct measurement up to 100A
- Communication**  
 -Interface: RS485  
 -Protocol: Modbus-RTU
- Energy Metering**  
 -Bi-directional energy  
 -Tariff energy

## APPLICATIONS



Energy Management



Sub-item Metering



Power Monitoring



# COMPARISON TABLE



Model	DDS1946-1P+	DDSF1946-1P+	DDS1946-2M	DDSF1946-2M	DDS1946-2P-M	DDSF1946-2P-M	DDS1946	DDSF1946	DDS1946-T	DDSF1946-T
<b>Wiring Method</b>	Up in down out				Down in down out					
<b>Accuracy</b>	Class 1	Class 1	Class B	Class B	Class 1	Class 1	Class 0.5	Class 0.5	Class 0.5S	Class 0.5S
<b>Wiring</b>	1P2W	1P2W	1P2W	1P2W	1P2W	1P2W	1P2W	1P2W	1P2W	1P2W
<b>Voltage</b>	230V	230V	230V	230V	230V	230V	230V	230V	230V	230V
<b>Current</b>	Direct	0.5-10(100)A	0.5-10(100)A	0.25-5(63)A	0.25-5(63)A	0.25-5(63)A	0.25-5(100)A	0.25-5(100)A	-	-
	Via CT	-	-	-	-	-	-	-	0.05-5(6)A	0.05-5(6)A
<b>Measuring</b>	Voltage	■	■	■	■	■	■	■	■	■
	Current	■	■	■	■	■	■	■	■	■
	Power	■	■	■	■	■	■	■	■	■
	Power factor	■	■	■	■	■	■	■	■	■
	Frequency	■	■	■	■	■	■	■	■	■
<b>Energy Metering</b>	±kWh	■	■	■	■	■	■	■	■	■
	Tariffs energy	-	■	-	■	-	■	-	■	■
<b>Width(mm)</b>	18	18	36	36	36	36	72	72	72	72
<b>Communicaton</b>	Modbus-RTU	■	■	■	■	■	■	■	■	■
	MBUS	-	-	-	-	■	■	-	-	-
<b>Energy Pulse</b>	-	-	■	■	■	■	■	■	■	■
<b>Display Mode</b>	LCD	LCD	LCD	LCD	LCD	LCD	LCD	LCD	LCD	LCD

NOTE: "■": Yes    "-": No

# COMPARISON TABLE

MID

MID



Model	DTS1946-4M	DTSF1946-4M	DTS1946-4M-T	DTSF1946-4M-T	DTS1946-4P-M	DTSF1946-4P-M	DTS1946-4P-TM	DTSF1946-4P-TM	DSS1946	DSSF1946	DSS1946-T	DSSF1946-T	DTS1946	DTSF1946	DTS1946-T	DTSF1946-T	
<b>Wiring Method</b>	Up in down out							Down in down out									
<b>Accuracy</b>	Class B	Class B	Class 0.5S	Class 0.5S	Class 1	Class 1	Class 0.5S	Class 0.5S	Class 0.5	Class 0.5	Class 0.5	Class 0.5S	Class 0.5S	Class 0.5	Class 0.5	Class 0.5S	Class 0.5S
<b>Wiring</b>	3P4W	3P4W	3P4W	3P4W	3P4W	3P4W	3P4W	3P4W	3P4W	3P3W	3P3W	3P3W	3P3W	3P4W	3P4W	3P4W	3P4W
<b>Voltage</b>	3*230/400V	3*230/400V	3*230/400V	3*230/400V	3*230/400V	3*230/400V	3*230/400V	3*230/400V	3*230/400V	3*400V	3*400V	3*400V	3*400V	3*230/400V	3*230/400V	3*230/400V	3*230/400V
<b>Current</b>	Direct	0.25-5(63)A	0.25-5(63)A	-	-	0.25-5(63)A	0.25-5(63)A	-	-	0.25-5(100)A	0.25-5(100)A	-	-	0.25-5(100)A	0.25-5(100)A	-	-
	Via CT	-	-	0.01-1(6)A	0.01-1(6)A	-	-	0.01-1(6)A	0.01-1(6)A	-	-	0.01-1(6)A	0.01-1(6)A	-	-	0.01-1(6)A	0.01-1(6)A
<b>Measuring</b>	Voltage	■	■	■	■	■	■	■	■	■	■	■	■	■	■	■	■
	Current	■	■	■	■	■	■	■	■	■	■	■	■	■	■	■	■
	Power	■	■	■	■	■	■	■	■	■	■	■	■	■	■	■	■
	Power factor	■	■	■	■	■	■	■	■	■	■	■	■	■	■	■	■
	Frequency	■	■	■	■	■	■	■	■	■	■	■	■	■	■	■	■
	THD	■	■	■	■	■	■	■	■	■	■	■	■	■	■	■	■
<b>Energy Metering</b>	±kWh	■	■	■	■	■	■	■	■	■	■	■	■	■	■	■	■
	Tariffs energy	-	■	-	■	-	■	-	■	-	■	-	■	-	■	-	■
<b>Width(mm)</b>	72	72	72	72	72	72	72	72	72	126	126	126	126	126	126	126	126
<b>Communicaton</b>	Modbus-RTU	■	■	■	■	■	■	■	■	■	■	■	■	■	■	■	■
	MBUS	-	-	-	-	■	■	■	-	-	-	-	-	-	-	-	-
<b>Energy Pulse</b>		■	■	■	■	■	■	■	■	■	■	■	■	■	■	■	■
<b>Display Mode</b>	LCD	LCD	LCD	LCD	LCD	LCD	LCD	LCD	LCD	LCD	LCD	LCD	LCD	LCD	LCD	LCD	LCD

NOTE: "■": Yes "—": No



## DIMENSIONS

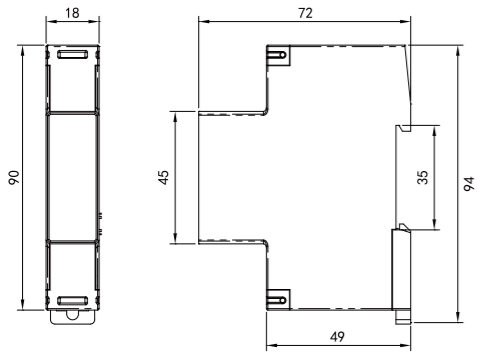

DDS1946-1P+  
DDSF1946-1P+

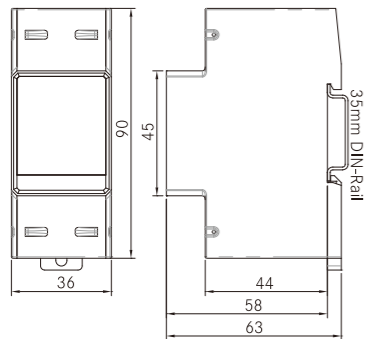

DDS(F)1946-2M  
DDS(F)1946-2P-M

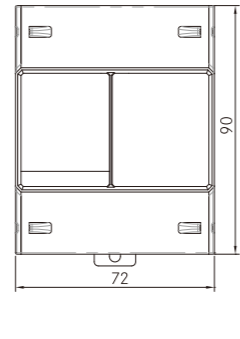

DTS(F)1946-4M  
DTS(F)1946-4M-T

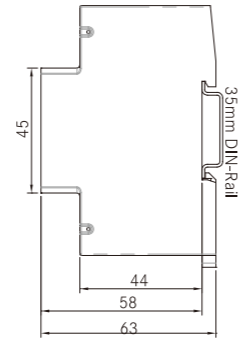

DTS(F)1946-4P-M  
DTS(F)1946-4P-TM

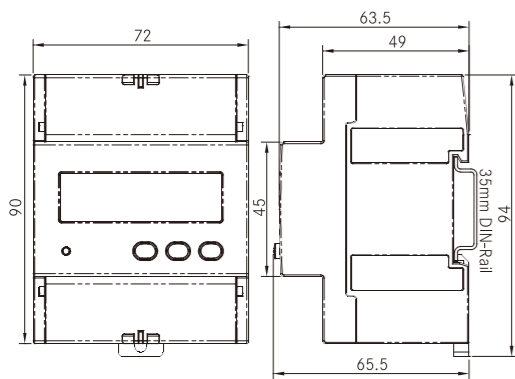

DDS(F)1946  
DDS(F)1946-T

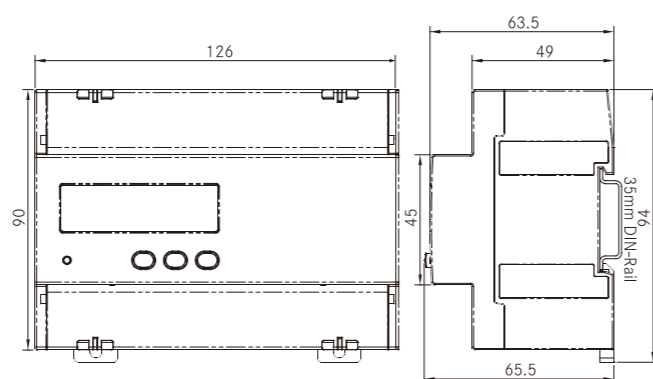

DSS(F)1946  
DSS(F)1946-T

DTS(F)1946  
DTS(F)1946-T



## TYPICAL WIRING

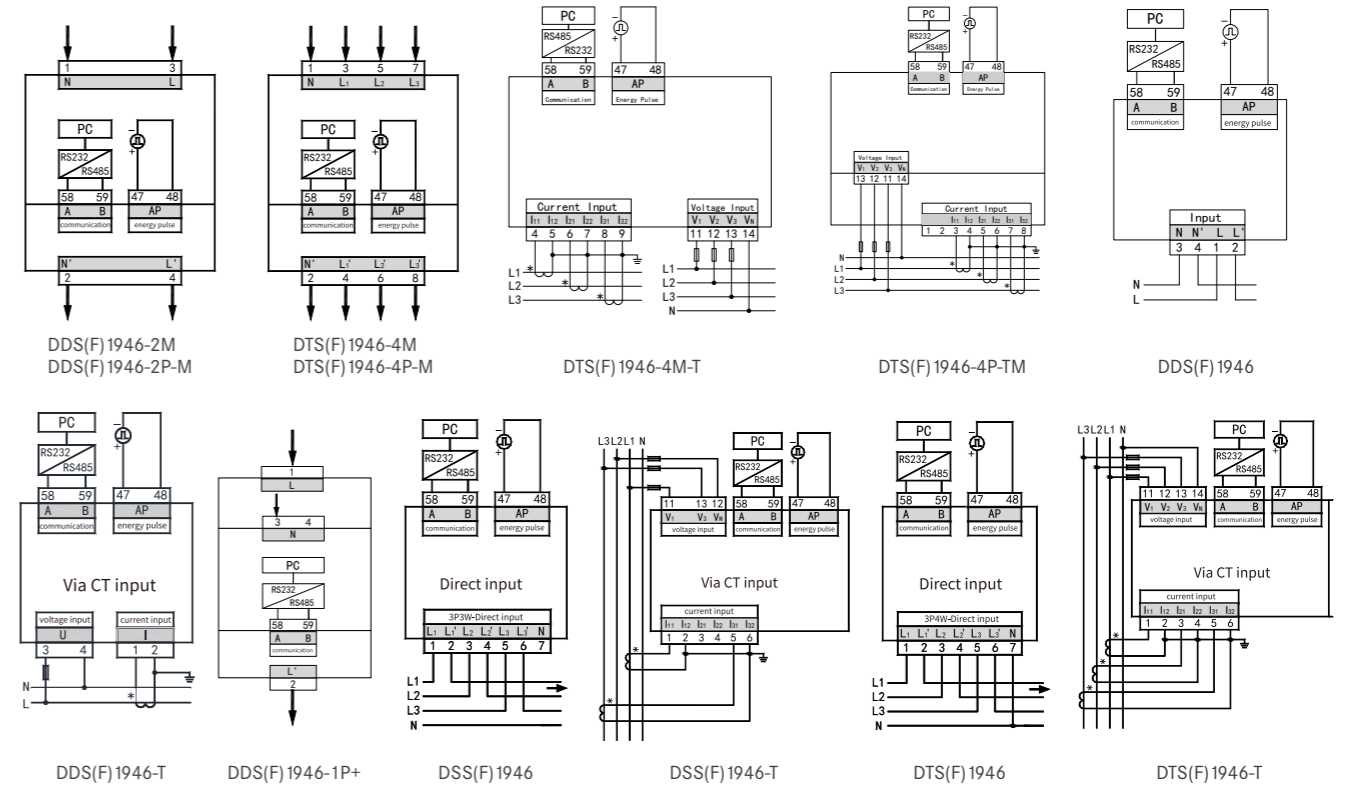

## TECHNICAL SPECIFICATION

Model	DDS/DSS/DTS1946 Series
Normal voltage	230V, 3*400V, 3*230/400V
Frequency	45Hz~65 Hz
Voltage range	0.8Un~1.2Un
Start current	Direct input: 0.004Ib Via CT input: 0.001In
Consumption	< 4VA
Energy pulse	1 output, pulse width (80±20%) ms
RTC error	≤ 0.5s/day
Communication	RS485, Modbus-RTU/ MBUS protocol
IP degree	Front:IP51
Operating temperature	-25 C ~55 C
Relative humidity	≤ 93%

# MULTI-CIRCUIT MONITORING SYSTEM

Digital Intelligent Power Distribution Solution Provider  
<http://en.sfere-elecnova.com>



## Sfere701



Specially designed for intelligent rack bus  
Multi-circuit real-time measurement  
Energy metering  
Power quality monitoring  
Electrical safety monitoring



### APPLICATIONS



Data Center



Telecommunications

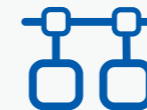

Rack Bus Monitoring



Energy management

## FUNCTION

Name	Model	Function
Display module	Sfere701-D10	To show measured data from measurement module, and be used to set parameter of measurement module.
Measurement module	Sfere701-M	Measure voltage, current, power, frequency, energy, demand, extreme value and harmonics of three-phase grid. 1 RS485 communication interface, 1 digital output, and external current transformers. Each module can be extended to one Sfere701-F.
Temperature module	Sfere701-F0	4-way temperature measurements.
Temperature & switch module	Sfere701-F1	4-way temperature measurements; 3-way digital input measurements.
Power supply module	Sfere701-P	Provide DC24V power supply to display and communication modules.

## MODEL

Function	Sfere701-M1A	
Real-time measurement	U, I, Hz, P, Q, S, PF	■
	Demand, max./ min. value, average value	■
Energy metering	Bi-direction energy, apparent energy	■
	Four-quadrant reactive energy	■
	Sub-phase energy	■
Power quality	THDu, THDi	■
	Individual harmonic ratio	2~31st
	Unbalance	■
	Crest factor, K factor	■
Data record	Voltage deviation, frequency deviation	■
	Demand record	■
	Max value, min value and average value record	■
	Off-limit alarm records	■

NOTE: "■": Yes

## TECHNICAL SPECIFICATION

Sfere701-M Ambient condition	
Working temperature	-20°C ~ 70°C
Relative humidity	≤ 95%RH, no condensation
Working altitude	≤ 2000m
Protection	IP20
Insulation	Signal, power supply and output terminal to case resistance > 100MΩ
Withstand voltage	≥ 2kV
Electromagnetic Compatibility	Better than Class III
Working power supply	
Rated range	AC/DC 80 ~ 270V 50/60Hz
Power consumption	≤ 0.5W
Voltage input	
Range	AC 3*230/400V
Resolution	0.1 V
Impedance	≥ 1.7 MΩ /phase
Consumption	≤ 0.1 VA /phase
Over-voltage	Continuous 1.2 times, Instantaneous: 2 times/10s
Frequency	45-65 Hz
Current input	
Range	External split-core/solid type CT
Communication port COM1	
Physical interface	RS485
Communication protocol	Modbus-RTU, up to 19200bps
Insulation voltage	4000 V AC
Communication port SBUS	
Physical interface	RS485
Communication port	Used to connect to Sfere701-F0/F1
Communication protocol	Modbus-RTU, up to 38400bps
Insulation voltage	4000 VAC

## TECHNICAL SPECIFICATION

Sfere701-D10	Specification
Display	10.1" TFT LCD touch screen, resolution 1024*600
Protection	IP65(Front panel)
Working temperature	0 C ~50 C
Relative humidity	≤ 90%RH (no condensation)
Working range	(24±20%)VDC
Consumption	6W

  

Sfere701-P	Specification
Input voltage	AC/DC: 80V ~270V
Output voltage	DC: 24V
Output power	≤ 20W
Accuracy	±1%
Efficiency	>75%
Withstand voltage	2000V AC

## RACK BUS MONITORING SOLUTION

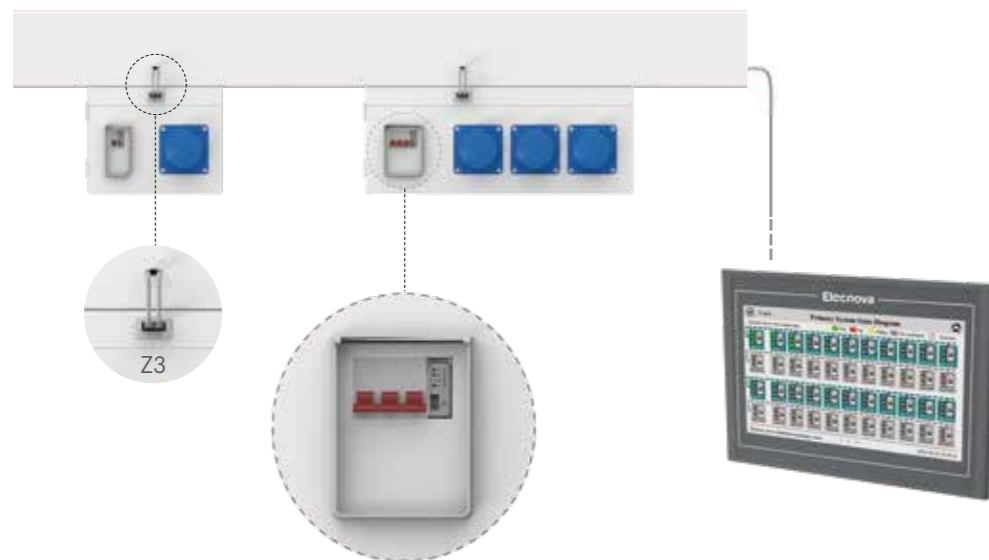

## TYPICAL WIRING

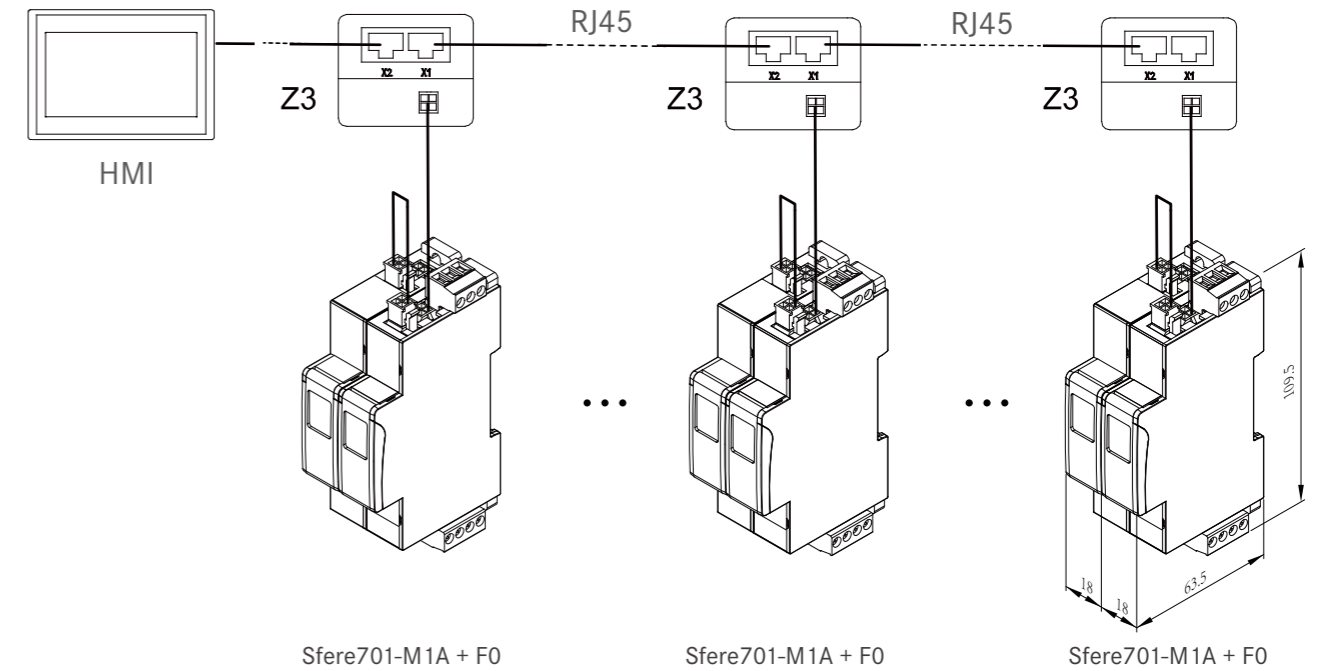

The measurement module can be equipped with various current transformers such as Solid-core CT, split-core CT, and Rogowski coil CT to adapt to various application scenarios.

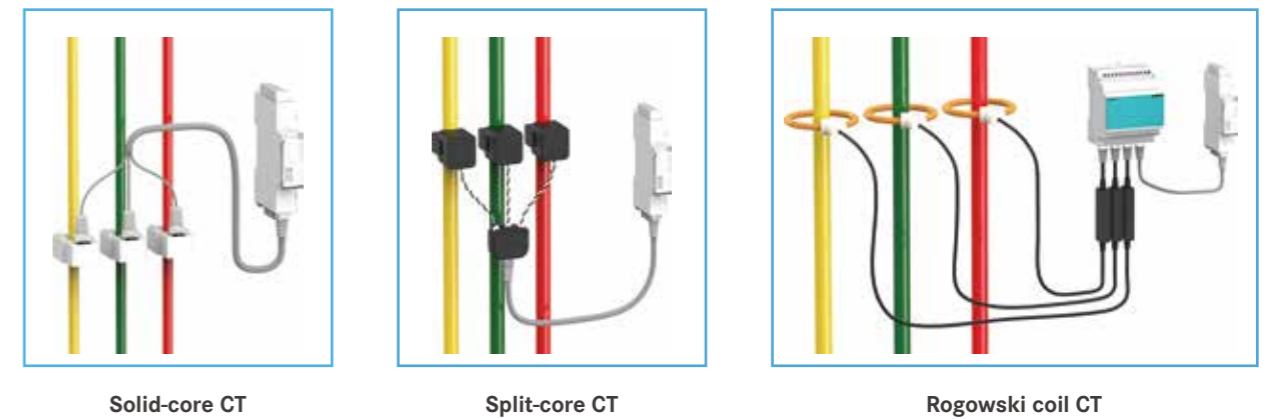

Solid-core CT components	T-BCTxx	High accuracy current measurement, optional rated values 5A, 100A, 200A, 400A, 600A
Split-core CT components	T-SCTxx	Continuous electrical measurement, optional rated values 5A, 100A, 200A, 400A, 600A
Rogowski coil CT components	T-FCTxx	High current measurement, optional rated values of 600A, 1000A, 2000A, 3000A

## CT MODEL



Solid-core CT					
Model	SHI-BCT50	SHI-BCT100	SHI-BCT200	SHI-BCT400	SHI-BCT600
Aperture (mm)	8	18	24	29	29
Outline dimension (mm)	28x18x44	36x20x59	60x20x80	75x22.5x95	75x22.5x95



Split-core CT					
Model	SHI-SCT50	SHI-SCT100	SHI-SCT200	SHI-SCT400	SHI-SCT600
Aperture (mm)	10	16	24	35	35
Outline dimension (mm)	31x38x43	36.5x40x50	51x47x70	57x41x84	67x52x83



Rogowski coil CT				
Model	SHI-FCT600	SHI-FCT1000	SHI-FCT2000	SHI-FCT3000
Aperture (mm)	65	95	95	95

# BCM101

## Precision Power Distribution Monitoring Unit



Real-time measurement  
Switch status monitoring  
Power quality monitoring  
Energy metering



## SYSTEM STRUCTURE

BCM101 AC precision distribution monitoring unit is used to monitor electrical parameters of array cabinet, to measure electrical parameters such as voltage, current, energy and harmonics of inlet and outlet branches and to monitor the switch status of all circuit breakers in data center.

BCM101 is equipped with trip alarm function and over current alarm function which can be set in every output circuit by two-level users so as to prevent potential power failure.

BCM101 is configured with 7-inch human-machine interface and Ethernet communication interface which makes it simple to be connected to other systems.

Support to monitor 2 three-phase incoming circuits and 120 single-phase feeder circuits at most.

## APPLICATIONS



Data Center



Telecommunications



Power monitoring



Energy management

## TYPICAL WIRING

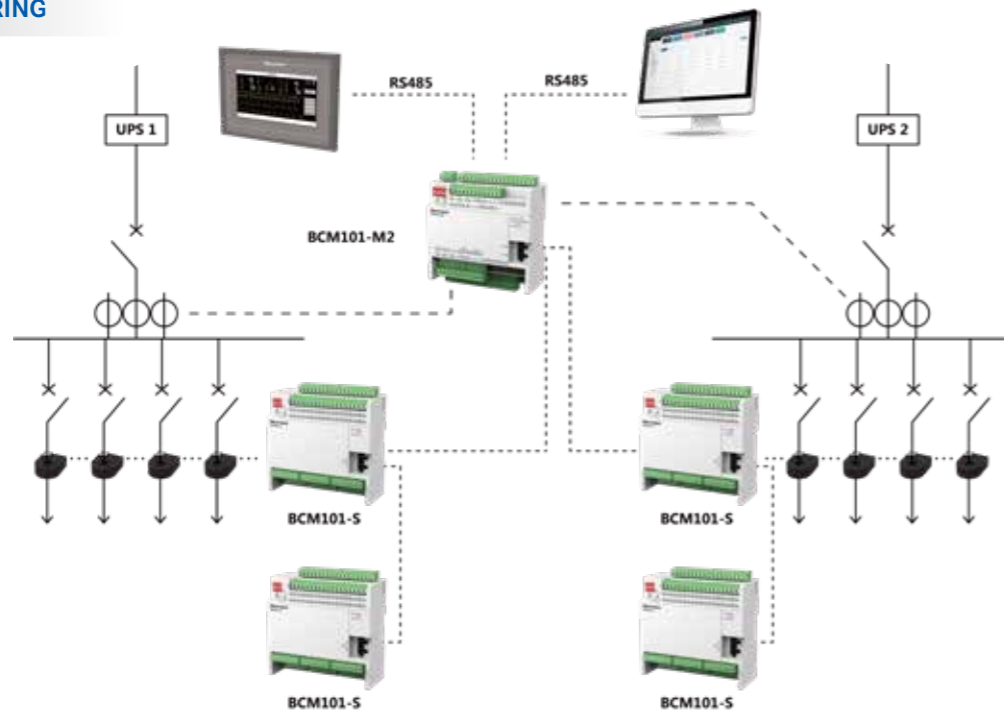

## FUNCTION

Name	Function
Main module (Incoming line monitoring module) <b>BCM 101-M1</b> <b>BCM 101-M2</b>	BCM101-M1 can measure the electrical parameters of one three-phase circuit, and BCM101-M2 can measure the electrical parameters of two three-phase circuits. The electrical parameters include voltage zero to earth voltage, current, power, frequency, energy, demand, extreme values, harmonics and temperature. The main modules are equipped with two RS485 communication ports, one Ethernet port for option, four digital inputs and two relay outputs; they are also equipped with two busbar interfaces which can be connected with feeder monitoring module and switch monitoring module. The main modules can record tariff energy and save the energy of ten years. They can record 1024 pieces of SOE event records, 1024 pieces of real-time alarm records and 12800 pieces of alarm records.
Slave module (Feeder monitoring module) <b>BCM 101-S</b>	BCM 101-S can measure the electrical parameters of thirty single-phase circuits. The electrical parameters include voltage, current, power, frequency, energy, demand, extreme values and harmonics. This module is equipped with busbar interface which is used to extend the module. It is also equipped with thirty digital inputs which can judge the opening and closing of circuit breaker through voltage values.
Switch monitoring module <b>BCM 101-K</b>	BCM101-K can monitor the status of sixty switches with wet contact input, It is equipped with two busbar interfaces which are used to extend this module.
Display module <b>BCM 101-HMI</b>	BCM101-HMI is used to display measuring electrical parameters of incoming line/feeder and status of circuit breaker.

## TECHNICAL SPECIFICATION



BCM101-M1  
BCM101-M2

Parameters		Specification	
Accuracy		U, I: 0.2 class, P, Q, PF: 0.5 class, Active energy: 0.5S	
Voltage	Rated value	Three-phase AC 3x230/400V, single phase AC 230V	
	Overload	Continuous: 1.2Un, Instantaneous: 2Un/1min	
Signal input	Rated value	AC5A/AC1A	
	Current	Overload	Continuous: 1.2In, Instantaneous: 10In/5s
	Frequency		45~65Hz, accuracy: ±0.01Hz
Digital input		4 Digital inputs, dry contact	
Relay output		2 relay outputs, AC 250V/5A DC 30V/3A (AC1)	
Temperature		2 temperatures, NTC	
Communication		2 RS485 communication ports, Modbus-RTU protocol (Optional)	
		1 RJ45 communication port, Modbus-TCP protocol	
Busbar interface		2	
Power supply	Working range	DC: 24V	
Installation dimension		L x W x H(mm): 126*133*50, DIN35mm rail mounted	



BCM101-SC

Parameters		Specification	
Accuracy		U, I: 0.2 class, P, Q, PF: 0.5 class, Active energy: 0.5S	
Voltage	Rated value	Phase AC 230V	
	Overload	Continuous: 1.2Un, Instantaneous: 2Un/1min	
Signal input	Others	30 digital inputs, judging the opening and closing of circuit breaker through voltage value. If voltage > 120V, circuit breaker closes; if voltage < 110V, circuit breaker opens.	
	Current	Rated value	50A
	Overload		Continuous: 1.2In, Instantaneous: 10In/5s
Frequency		45~65Hz, accuracy: ±0.01Hz	
Installation dimension		L x W x H(mm): 126*125*50, DIN35mm rail mounted	



Current transformer module

Parameters		Specification
Rated value		SHI-BCT50 II : 5(50)A, SHI-BCT100 II : 5(100)A
Accuracy		Class 0.1
Overload		Continuous: 1.2In, Instantaneous: 10In/5s
Power consumption		≤ 0.2VA (each phase)
Impedance		≤ 20mΩ
Insulation		4000V/min
Installation dimension		5(50)A - LxWxH(mm): 26*33.5*11.5, pore diameter: φ 8.9mm
		5(100)A - LxWxH(mm): 45*52.5*17.5, pore diameter: φ 19mm



# PD194Z-E14



Multi-circuit  
Harmonics  
Modbus Interface  
Energy Accuracy 0.5S  
Pulse Output



## FUNCTION

### Networks

-TN, TT, IT networks

### Accuracy

-Energy: 0.5S(Solid-core CT)  
-Voltage: 0.2%  
-Current:0.2%

### Communication

-Interface: RS485  
-Protocol: Modbus-RTU

### Measuring

-Fundamental V/A  
-Demand  
-Max./Min. Value

### Energy Metering

-Bi-directional energy  
-Four-quadrant reactive energy  
-Tariff energy  
-Fundamental energy

### Power Quality

-THD  
-Harmonics up to 31st  
-Sequence component  
-Unbalance  
-Crest factor and K factor

## APPLICATIONS

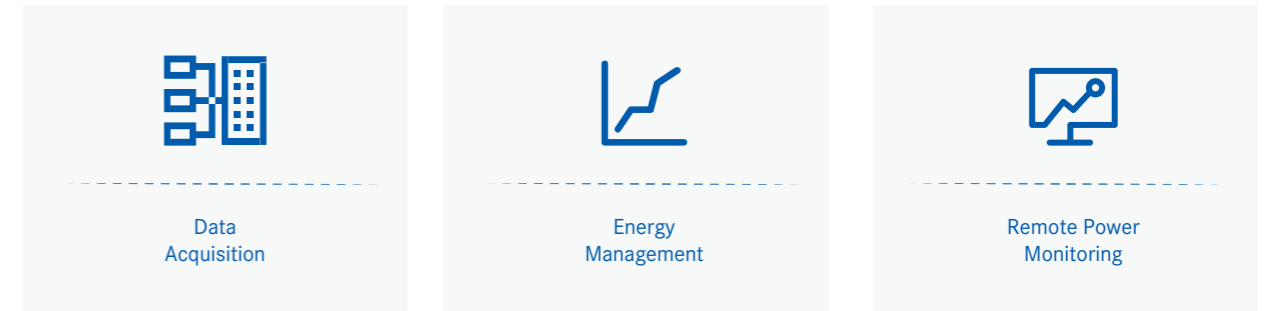

## DIMENSIONS

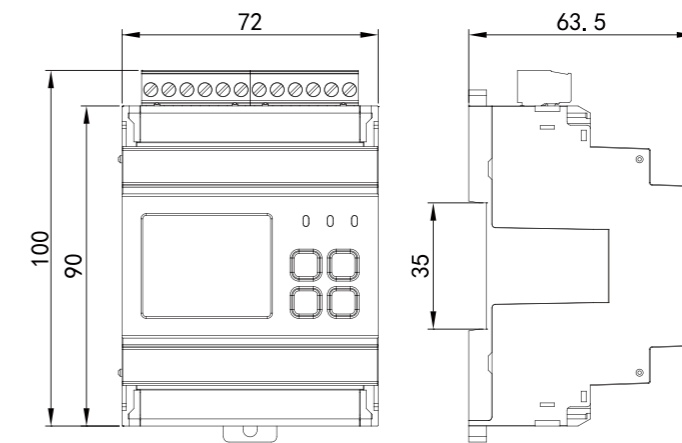

PD194Z-E14

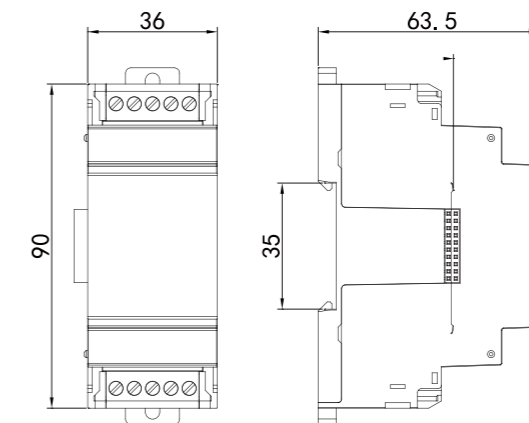

EK1

## TYPICAL WIRING

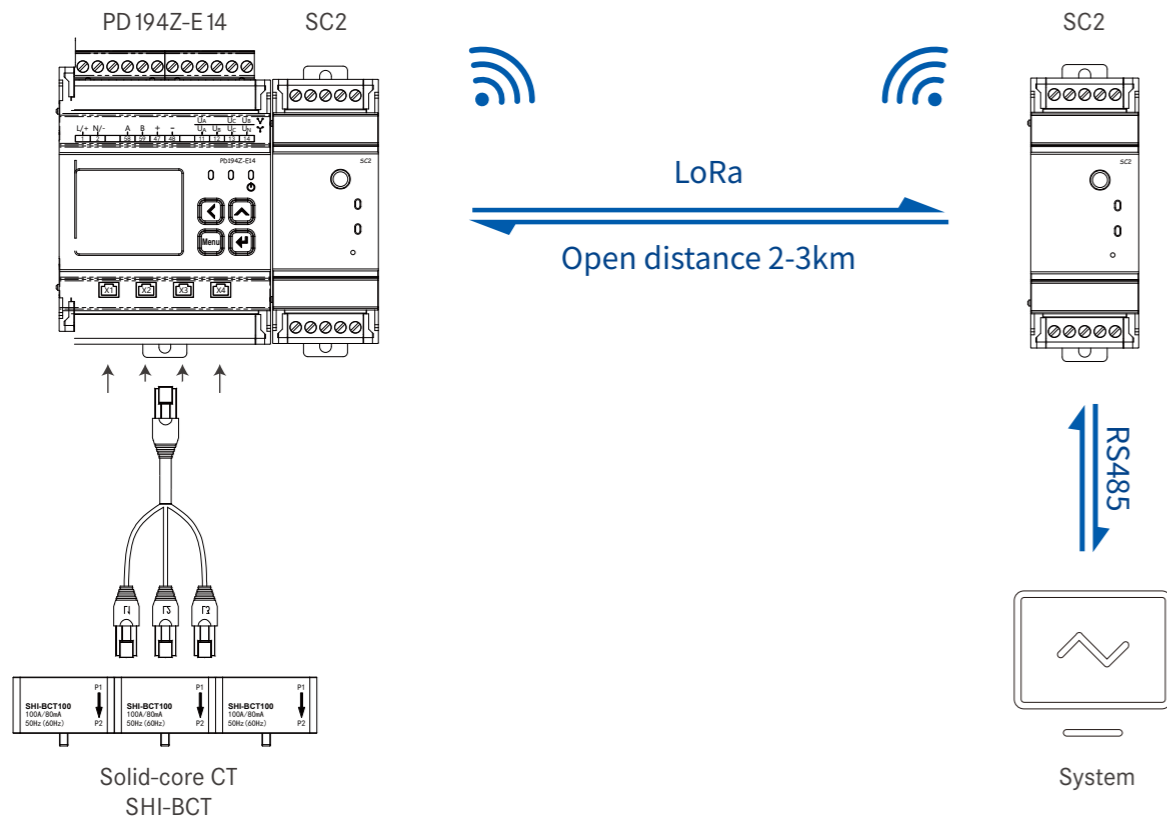
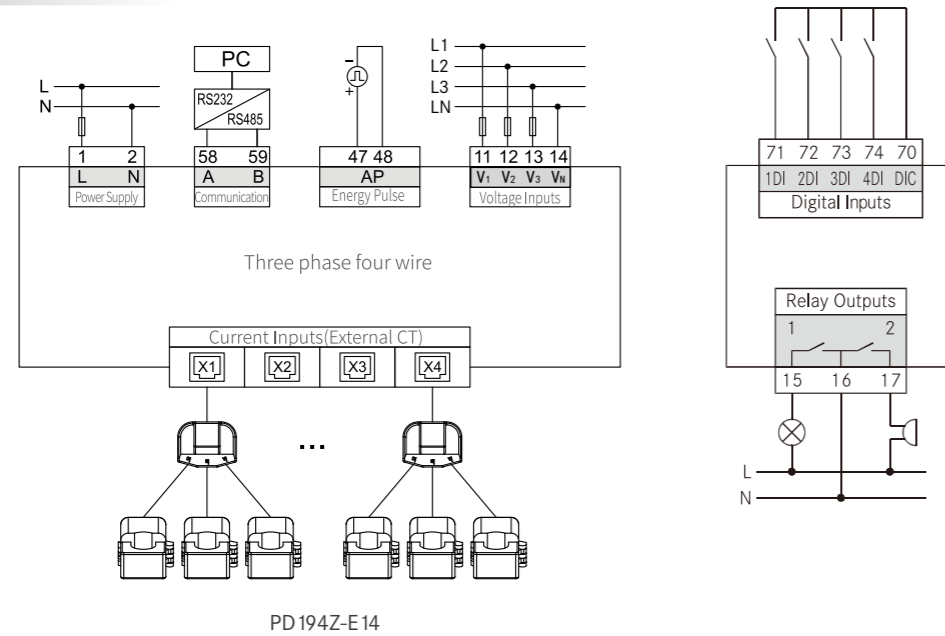

## TECHNICAL SPECIFICATION

<b>Display mode</b>		LCD
<b>Accuracy</b>	V/A	0.2%
	P/Q/S/PF	0.5%
	F	±0.01Hz
	±kWh	Class 0.5S (Closed Type CT)
<b>Voltage input</b>	±kvarh	Class 2
	Rated value	3*230V/400V
	Overload	Continuous: 1.2Vn Instantaneous:2Vn/10s
	Burden	≤0.1VA (per phase)
	Impedance	≥1.7MΩ
<b>Current input</b>	Frequency	45Hz~65Hz
	Rated value	External CT
	Overload	Continuous: 1.2In Instantaneous: 2In/5s
	Burden	≤0.2VA (per phase)
	Impedance	≤20mΩ
<b>Auxiliary power supply</b>	Working range	AC/DC 80~270V 50/60Hz
	Consumption	≤5VA
<b>Communication port</b>	RS485	Modbus-RTU, 2-wire, up to 9600bps
<b>Energy pulse output</b>		1 photocoupler output, pulse width (80±20%) ms
<b>Optional module(EK1)</b>	Digital inputs	Dry digital inputs, Isolation: ≥2kV AC
	Relay outputs	Contact rated at AC 250V/5A or DC 30V/5A (AC 1)
<b>Ambient condition</b>	Operating temperature	-20°C~70°C
	Relative humidity	≤95%RH, no condensation
	Altitude	≤2500m
<b>Insulation</b>		≥2kV AC

# ENERGY METER FOR EV CHARGER

Digital Intelligent Power Distribution Solution Provider  
<http://en.sfere-elecnova.com>



## PD195Z-CD31F



Programmable  
Wide Range of Working Temperature  
High DC Voltage Input



### FUNCTION

- ◉ **Networks**
  - DC networks
- ◉ **Accuracy**
  - Voltage: 0.5%
  - Current: 0.5%
  - Energy: Class 1
- ◉ **Communication**
  - Interface: RS485
  - Protocol: Modbus-RTU

### MAIN FEATURES

- ◉ **Measuring**
  - V/A/P
- ◉ **Energy Metering**
  - Active energy
  - Tariffs

### APPLICATIONS



Solar Power  
Generation



EV  
Charger



Remote Power  
Monitoring

## DIMENSIONS

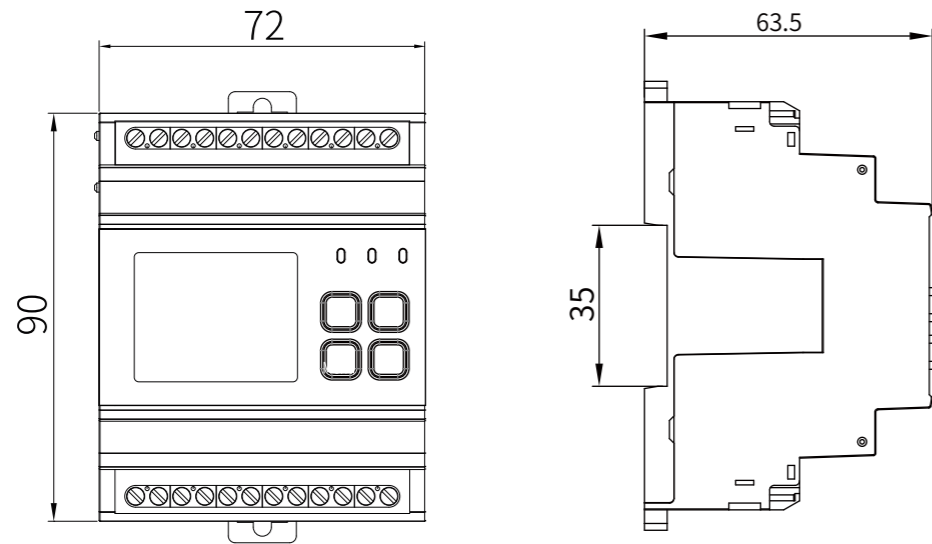

## TYPICAL WIRING

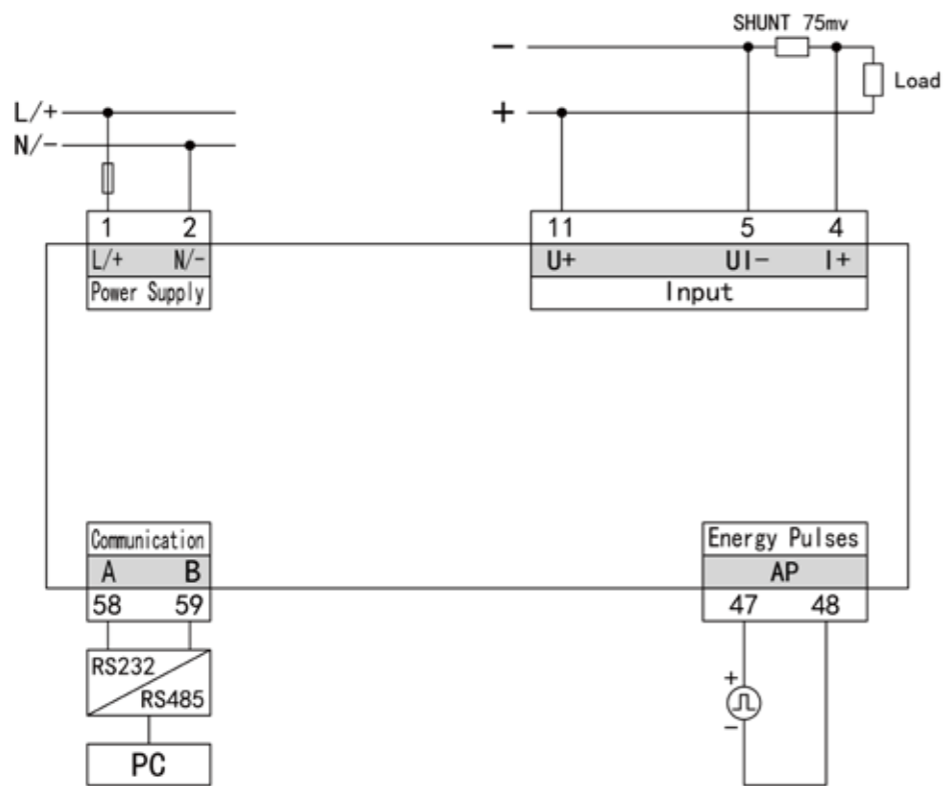

## TECHNICAL SPECIFICATION

Electrical Characteristics		
<b>Accuracy</b>		Voltage, current: Class 0.5, Power: Class 1 Energy: Class 1
<b>Voltage input</b>	Rated voltage $U_n$	DC 1000V CATII
	Over voltage	Continuous: $1.2U_n$
	Power consumption	$\leq 0.2$ W
<b>Current input</b>	Rated value $I_n$	75mV (input via shunt)
	Minimum current	$0.05I_n$
	Maximum current	$1.2I_n$
	Start-up current	$0.004I_n$
	Power consumption	$\leq 0.1$ W
Working power supply		
Rated range		AC/DC: 80~270V or DC: 9~36V
Power consumption		$\leq 5VA$ or $\leq 2W$
Communication characteristics		
RS485 communication port		Modbus-RTU protocol, baud rate up to 38400bps
Output interface		
Energy pulse		Pulse width $80ms \pm 20ms$
Real-time clock		
Error		$\leq 0.5s/24h$
Mechanical characteristics		
Dimension(mm)		$72 \times 90 \times 63.5$
IP protection		Front case: IP54, rear case IP20
Ambient condition		
Working temperature		$(-40 \sim 70)^\circ C$
Relative humidity		$(5 \sim 95)\%$ (no condensation)
Altitude		$\leq 2000m$
Comply to standards		
Safety		IEC61010-1
EMC		IEC61326-1

# PD195Z-CD32F



Programmable  
Wide Range of Working Temperature  
High DC Voltage Input



## FUNCTION

- **Networks**
  - DC networks
- **Accuracy**
  - Voltage: 0.5%
  - Current: 0.5%
  - Energy: Class 1
- **Communication**
  - Interface: RS485
  - Protocol: Modbus-RTU

## MAIN FEATURES

- **Measuring**
  - Fundamental V/A
  - Demand
  - Max./Min. Value
- **Energy Metering**
  - Active energy
  - Tariffs

## APPLICATIONS



Solar Power Generation



EV Charger



Remote Power Monitoring

## MODEL

Product model	Measurement (2 channels)				Communication	Energy pulse
	Voltage U	Current I	Power P	Energy E		
PD195Z-CD32F	DC 1000V	DC 75mV	■	■	1 channel	2 channels

NOTE: "■": Yes

## DIMENSIONS

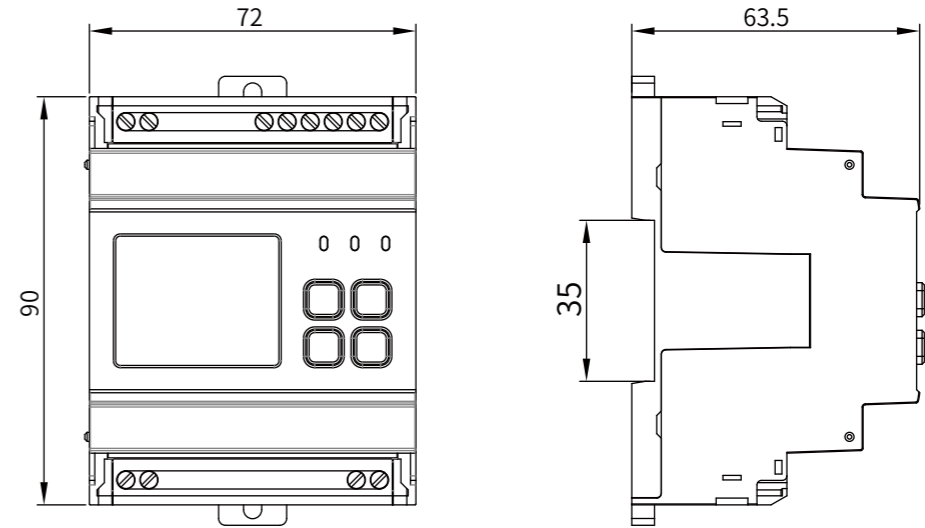

## TYPICAL WIRING

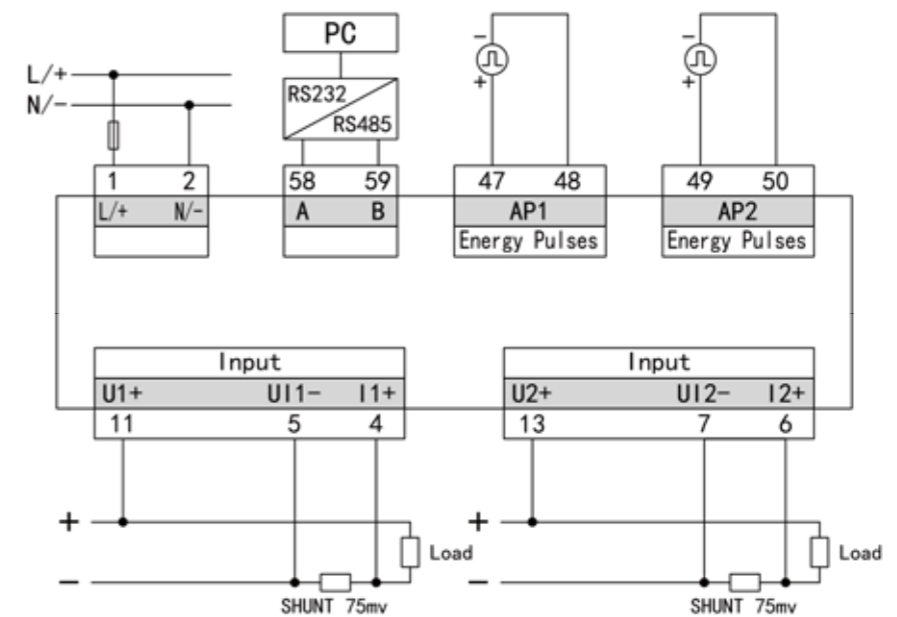

## TECHNICAL SPECIFICATION

Electrical characteristics		
<b>Accuracy</b>		
		Voltage, current: Class 0.5, Power: Class 1 Energy: Class 1
<b>Voltage input</b>	Rated voltage Un	DC 1000V CATII
	Over voltage	Continuous: 1.2Un
	Power consumption	≤0.2 W
<b>Current input</b>	Rated value In	75mV (input via shunt)
	Minimum current	0.05In
	Maximum current	1.2In
	Start-up current	0.004In
	Power consumption	≤0.1 W
	<b>Working power supply</b>	
Rated range	AC/DC: 80~270V or DC: 9~36V	
Power consumption	≤5VA or ≤2W	
<b>Communciation characteristics</b>		
RS485 communication port	Modbus- RTU protocol, baud rate up to 38400bps	
<b>Output interface</b>		
Energy pulse	Pulse width 80ms±20ms	
<b>Real-time clock</b>		
Error	≤0.5s/24h	
<b>Mechanical characteristics</b>		
Dimension(mm)	72×90×63.5	
IP protection	Front case: IP54, rear case IP20	
<b>Ambient condition</b>		
Working temperature	(-40~70)°C	
Relative humidity	(5~95)%(no condensation)	
Altitude	≤2000m	
<b>Comply to standards</b>		
Safety	IEC61010-1	
EMC	IEC61326-1	

# DTSF1946-4M-01



Programmable  
Wide Range of Working Temperature (-40~70 °C)  
MID Certification



## FUNCTION

- ◉ **Wiring**  
-Down in and up out
- ◉ **Accuracy**  
-Active energy Class index B
- ◉ **Communication**  
-Interface: RS485  
-Protocol: Modbus-RTU

## MAIN FEATURES

- ◉ **Measuring**  
-V/A/P/Q/PF/F/±kWh
- ◉ **Energy Metering**  
-Bi-directional energy  
-Tariffs

## APPLICATIONS



Intelligent Buildings



EV Charger



Remote Power Monitoring

## DIMENSIONS

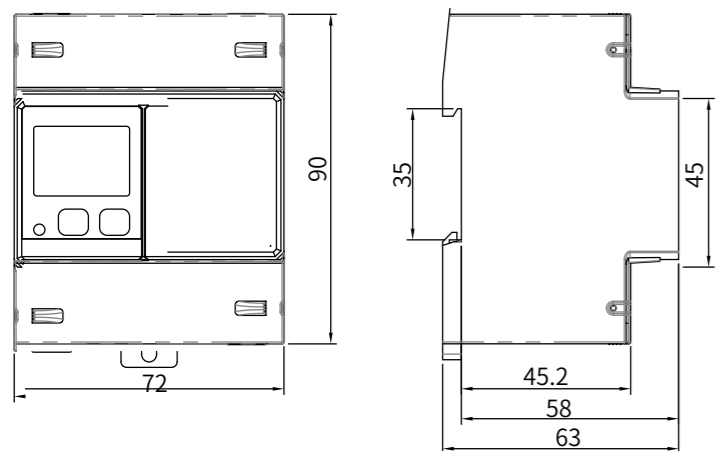

## TYPICAL WIRING

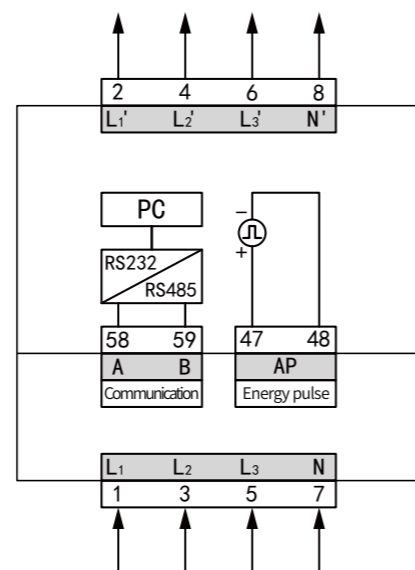

DTS1946-4M-01(Three phase, down in and up out)

## MODEL

Function	DTSF1946-4M-01	
<b>Wiring</b>	3P4W	■
<b>Voltage</b>	3×230/400V	■
<b>Current</b>	Direct	0.25-5(63)A
<b>Real-time measurement</b>	U, I, P, Q, S, PF, Hz	■
	THD	■
<b>Energy metering</b>	Bi-directional energy	■
	Four-quadrant reactive energy	■
	Tariff energy	■
<b>Demand</b>		■
<b>Max/Min value</b>		■
<b>Event log</b>		■
<b>RS485 Interface</b>		■
<b>Energy pulse</b>		■
<b>Display</b>		LCD

NOTE: "■": Yes

## TECHNICAL SPECIFICATION

Electrical characteristics		
Accuracy class		Class B
Rated voltage		3*230/400V
Frequency		50/60 Hz
Wiring mode		3P4W
Operating voltage range		0.8Un ~ 1.2Un
Power consumption	Power consumption of voltage circuit	<4VA
	Power consumption of current circuit	<1VA
Energy pulse		1 channel active energy pulse, pulse width 80ms±20%
Clock error		≤ 0.5s/day
Communication characteristics		
RS485 communication interface		Modbus RTU communication protocol, baud rate up to 9600bps
Mechanical properties		
Dimensions(mm)		72×90×63.5
IP protection		IP20
Ambient condition		
Working temperature		- 25 °C ~ +70 °C
Relative humidity		(5~95)%, Non condensing
Operating altitude		Altitude ≤ 2000m
Pollution degree		No corrosive gas
Insulation		Resistance of signal, power supply and output terminals to case ≥ 100MΩ

# DDSF1946-2M



Programmable  
MID Certification



## FUNCTION

- Accuracy
  - Active energy Class index B
- Communication
  - Interface: RS485
  - Protocol: Modbus-RTU

## MAIN FEATURES

- Measuring
  - V/A/P/Q/PF/F/±kWh
- Energy Metering
  - Bi-directional energy
  - Tariffs

## APPLICATIONS



Intelligent  
Buildings



EV  
Charger



Remote Power  
Monitoring

## DIMENSIONS

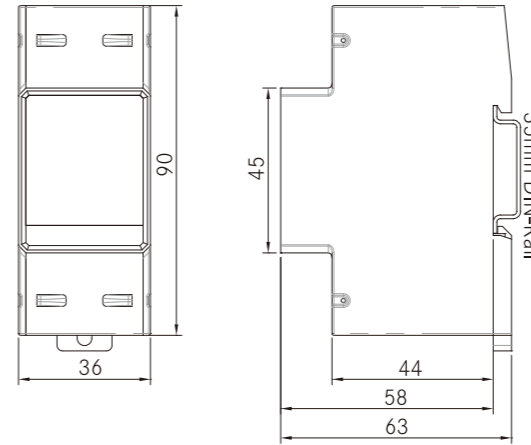

## TYPICAL WIRING

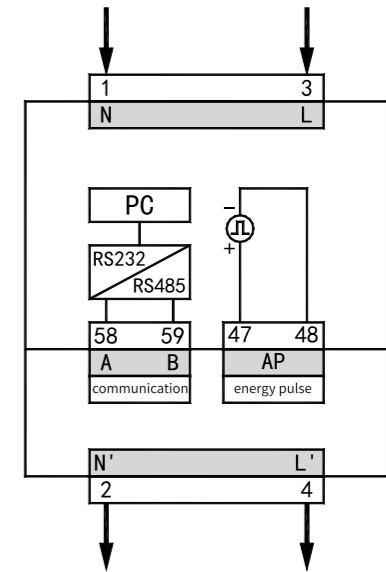

## MODEL

Function	DDSF1946-2M	
Wiring	1P2W	■
Voltage	230V	■
Current	Direct	0.25-5(63)A
Real-time measurement	U, I, P, Q, S, PF, Hz	■
Energy metering	Bi-directional energy	■
	Four-quadrant reactive energy	■
	Tariff energy	■
Demand		■
Max/Min value		■
Event log		■
RS485 Interface		■
Energy pulse		■
Display		LCD

NOTE: ■: Yes



## TECHNICAL SPECIFICATION

Electrical characteristics		
Accuracy class		Class B
Rated voltage		230V
Frequency		50/60 Hz
Wiring mode		Single-phase
Operating voltage range		0.8Un ~ 1.2Un
Power consumption	Power consumption of voltage circuit	<4VA
	Power consumption of current circuit	<1VA
Energy pulse		1 channel active energy pulse, pulse width
Clock error		≤ 0.5s/day
Communication characteristics		
RS485 communication interface		Modbus RTU communication protocol, baud rate up to 9600bps
Mechanical properties		
Dimensions(mm)		36×90×63.5
IP protection		IP20
Ambient condition		
Working temperature		- 25 C ~ +70 C
Relative humidity		(5 ~ 95)%, Non condensing
Operating altitude		Altitude ≤ 2000m
Pollution degree		No corrosive gas
Insulation		Resistance of signal, power supply and output terminals to case ≥ 100MΩ

# DC MULTI-FUNCTIONAL POWER METER

Digital Intelligent Power Distribution Solution Provider

<http://en.sfere-elecnova.com>



# PD195E-5SY1



Programmable  
Wide Range of Working Temperature  
High Protection Level  
High DC Voltage Input

## FUNCTION

- Accuracy
  - Voltage: 0.5%
  - Current: 0.5%
- Communication
  - Interface: RS485
  - Protocol: Modbus-RTU

## MAIN FEATURES

- Measuring
  - Fundamental V/A/P/E
- I/O
  - Analog outputs
  - Digital inputs
  - Relay outputs

## APPLICATIONS



Solar Power Generation



Industrial Control



Remote Power Monitoring

## DIMENSIONS

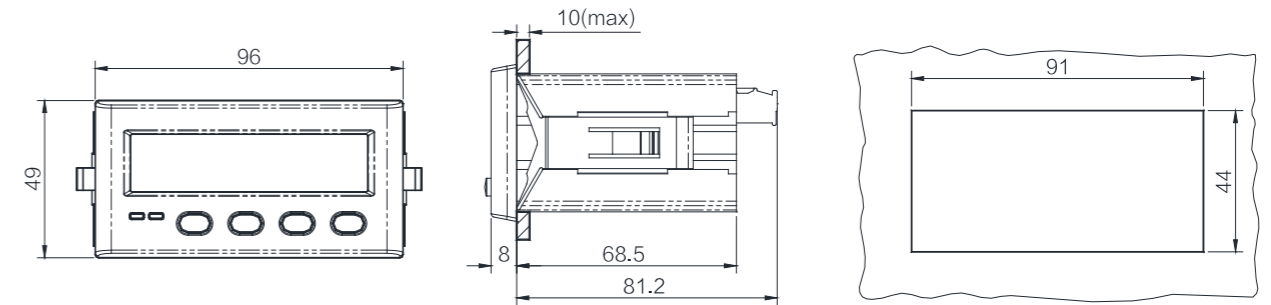

## TYPICAL WIRING

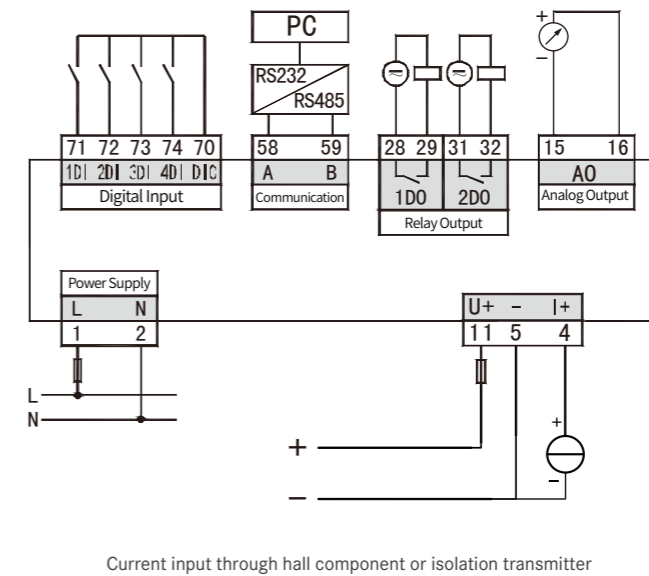
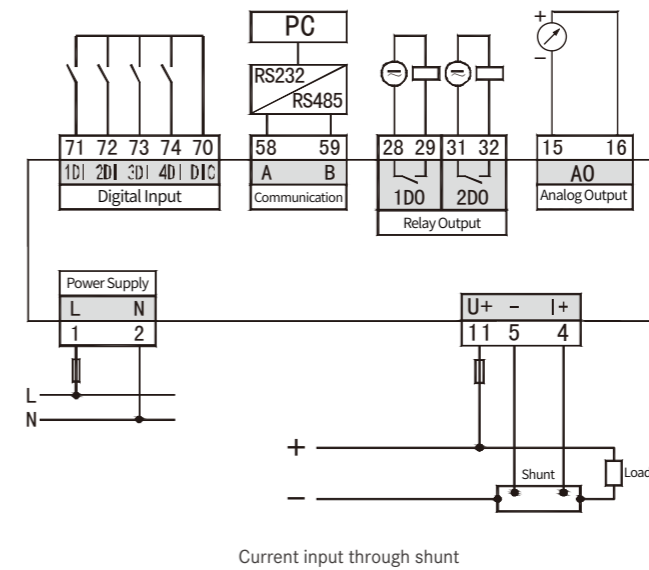

## TECHNICAL SPECIFICATION

Item	Parameter	
Accuracy class	U, I, P Class 0.5, energy Class 1	
Display data update time	1s	
Input characteristics	Voltage	Rated value
		Overload
	Current	Rated value
		Overload
Power supply	Working range	AC/DC 80~270V 50/60Hz
	Power consumption	≤5VA
Digital input	≤0.1mW (each channel)	
Relay output	Contact Capacity AC 5A/250V, DC 5A/30V (AC 1)	
Analog output	Current output	DC 4~ 20mA, 0~ 20mA and etc. load ≤350Ω
	Voltage output	DC 0~5V, 1~5V and etc. load ≥20kΩ
Communication	RS-485 interface, Modbus-RTU protocol, baud rate 2400~9600bps	
Protection level	IP64(Front panel), IP20(Rear case)	
Working temperature	-10~55°C	
Relative humidity	≤93%RH	
Insulation ability	Power supply, input and output ≥ AC 2kV	
Altitude	≤2500m	

# PD195Z-E33



Programmable  
Optional Modules  
DIN Rail Mounted



## FUNCTION

- Accuracy
  - Voltage: 0.5%
  - Current: 0.5%
- Communication
  - Interface: RS485
  - Protocol: Modbus-RTU

## MAIN FEATURES

- Measuring
  - V/A/P/E
- I/O
  - Digital inputs/Relay outputs(add EK1 module)
  - Measure up to 21 circuits(add EM2D modules)

## APPLICATIONS



Wind Power  
Generation



Industrial  
Control



Remote Power  
Monitoring

## DIMENSIONS

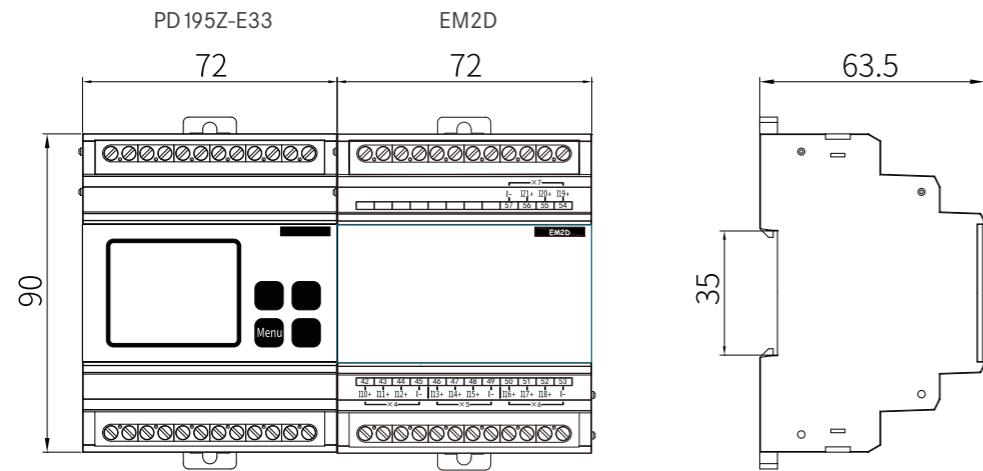

## TYPICAL WIRING

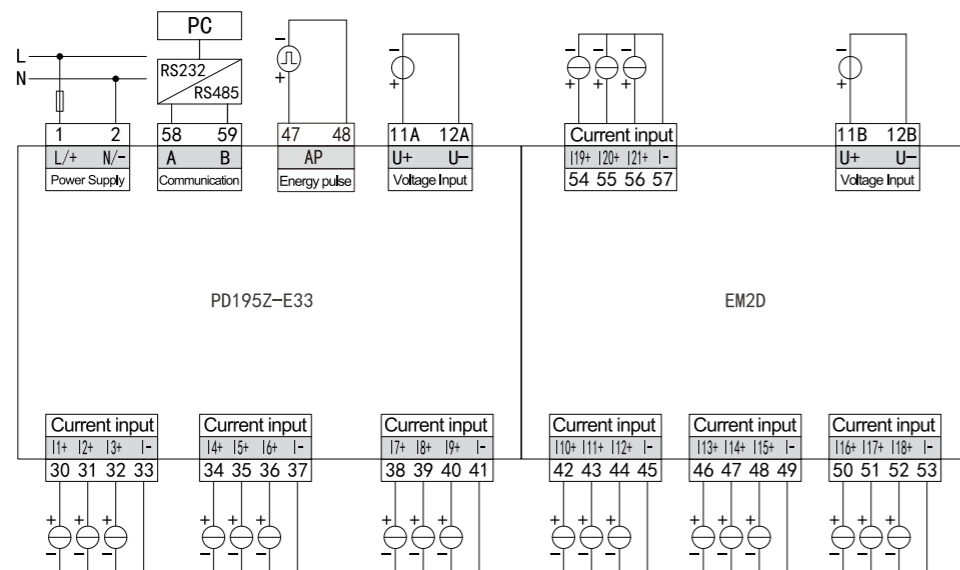

## TECHNICAL SPECIFICATION

Item	Parameter		
<b>Accuracy class</b>	Measuring module: U, I, P Class 0.5, Energy Class 1 Measuring module+ Hall sensor: U Class 0.5, I, P Class 1, Energy Class 2		
<b>Display mode</b>	LCD		
<b>Signal input</b>	Voltage	Rated value	DC(40 ~ 1000)V direct access
		Overload	Continuous: 1.2Vn
		Power consumption	≤0.2W
	Current	Impedance	≥6MΩ
		Rated value	DC(0 ~ 4)V(External hall sensor) Continuous: 1.2In
		Overload	Continuous: 1.2In
<b>Power supply</b>	Working Range	AC/DC 80~270V 50/60Hz	
	Power consumption	≥5VA	
<b>Communication</b>	RS-485 interface, Modbus-RTU protocol, communication rate up to 9600bps, higher rate can be customized		
<b>Digital input</b>	Optocoupler isolation, dry contact type(Optional EK1 module)		
<b>Relay output</b>	Capacity: AC250V/5A, DC30V/5A (AC 1) (Optional EK1 module)		
<b>Working temperature</b>	-20~ 70°C, ≤93%RH, altitude: ≤4000m		
<b>Protection level</b>	IP50 (Front panel), IP20 (Rear Case)		
<b>Safety</b>	Insulation	Signal, power supply, output terminal to case resistance ≥100MΩ	
	Withstand voltage	Power supply, input and output ≥AC2kV	

# DIGITAL POWER METER

Digital Intelligent Power Distribution Solution Provider  
<http://en.sfere-elecnova.com>



## LNF90 Series



Ultra-thin Design  
Bracket Free Installation  
LED Display  
High-level Protection



### FUNCTION

#### Accuracy

- Voltage: 0.5%
- Current: 0.5%

#### Communication

- Interface: RS485
- Protocol: Modbus-RTU

### APPLICATIONS



Control System



Smart Building



Power Transformation and Distribution Automation



Industrial Automation

## MODEL



**LNF90U3**

**LNF90I**

**LNF90I3**

	LNF90U3	LNF90I	LNF90I3
Dimension(mm)	96×96×34	96×96×34	96×96×34
Real-time measurement	Three-phase voltage	Single-phase current	Three-phase current
LED display	■	■	■
RS485	■	■	■

NOTE: "■": Yes

## DIMENSIONS

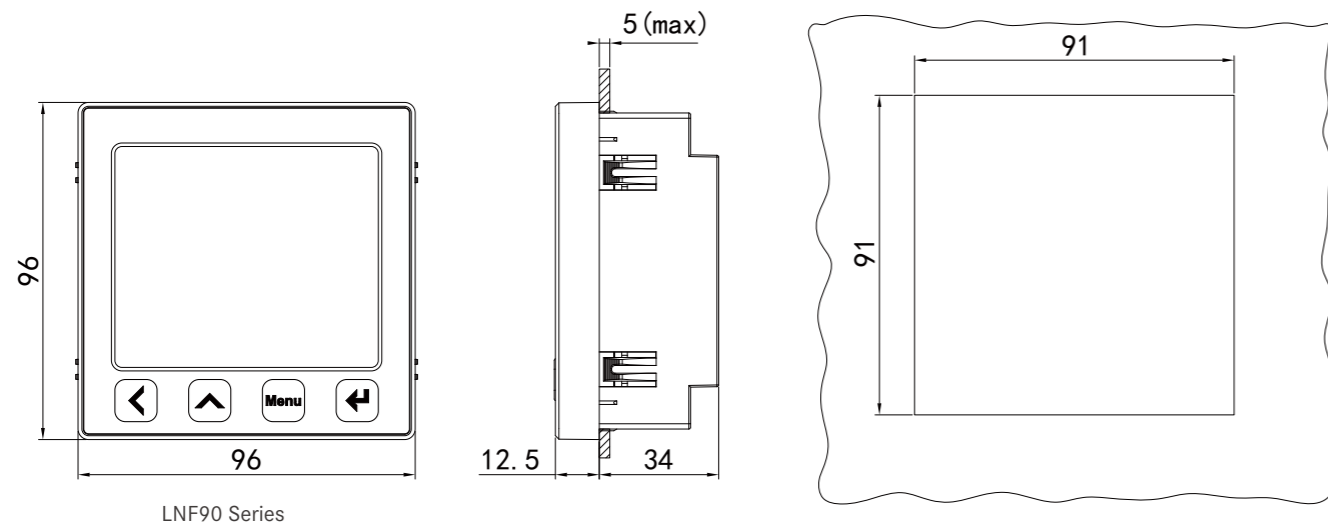

LNF90 Series

## TYPICAL WIRING

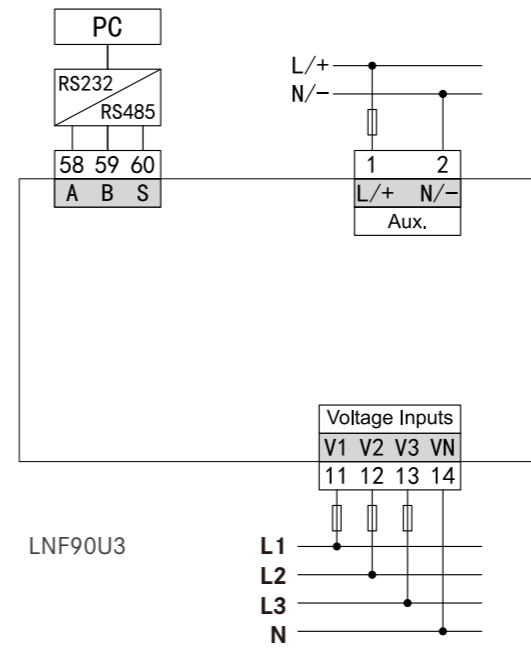

LNF90U3

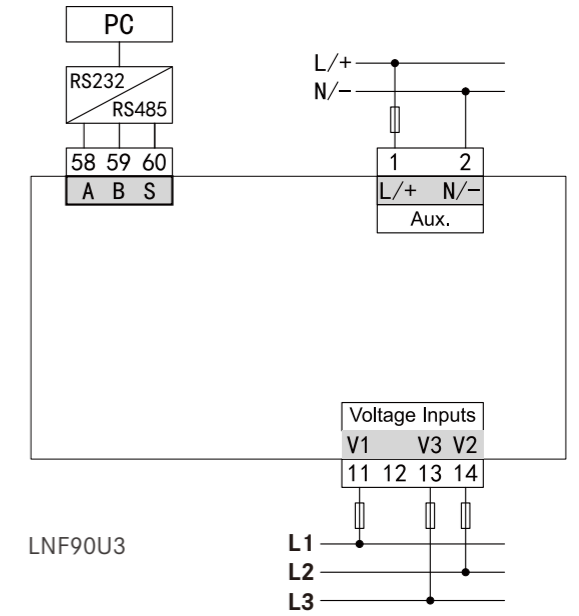

LNF90U3

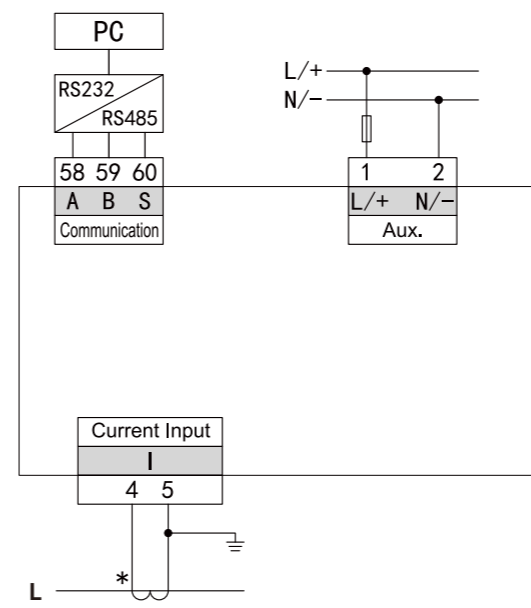

LNF90I

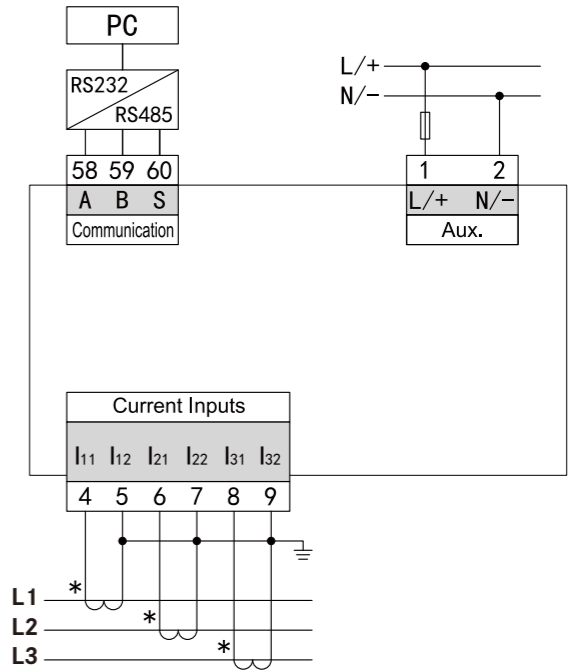

LNF90I3

## TECHNICAL SPECIFICATION

Item	Parameter	
Display mode	LED	
Accuracy	Voltage, current: 0.5%; Frequency: ±0.01Hz	
Current input	Range	5A/1A
	Resolution	1mA
	Impedance	< 20mΩ/phase
	Power consumption	< 0.2 VA/phase
	Over current	Continuous: 1.2In; Instantaneous: 10In/5s
	Frequency	45Hz~65Hz
	Voltage input	Range
Resolution		0.1 V
Impedance		> 1.7 MΩ/phase
Power consumption		≤0.1 VA /phase
Over voltage		Continuous: 1.2Vn; instantaneous: 2Vn/1min
Frequency		45Hz~65Hz
Communication port		Physical interface
	Communication speed	Up to 9.6 kbps
	Communication protocol	Modbus-RTU
	Isolation voltage	2000 VAC (1 min)
Working power supply	Rated range	AC/DC 80~270V 50/60Hz
	Power consumption	≤3VA
	Withstand voltage	≥2kV
Ambient condition	Working temperature	-10°C~55°C
	Relative humidity	≤95%RH, no condensation
	Working altitude	≤2500m
	Anti-pollution degree	No corrosive gas
	Protection degree	Front case IP54, rear case IP20
	Insulation	Resistance between signal, power supply, output terminals and case >100MΩ
	Withstand voltage	Input and power supply ≥2kV, input and output ≥2kV, power supply and output ≥2kV

## LNF70 series



Ultra-thin Design  
Bracket Free Installation  
LCD Display  
High-level Protection



This series of digital display AC electrical measurement meters are applied for voltage and current measurement in power distribution system. They support programmable transformation ratio and can be equipped with communication interface. They are featured with good appearance and compact structure.

## FUNCTION

### Accuracy

- Voltage: 0.5%
- Current: 0.5%
- Overload: 1.2Un, 1.2In

### Communication

- Interface: RS485
- Protocol: Modbus-RTU

## APPLICATIONS



Intelligent Device



Smart Building

# INC

Industrial and Mining Enterprise



Public Facilities

## MODEL



	LNF701Y-C	LNF7013Y-C	LNF70U3Y-C
Dimension(mm)	72x72x44.5	72x72x44.5	72x72x44.5
Real-time measurement	Single-phase current	Three-phase current	Three-phase voltage
LCD Display	■	■	■
RS485	■	■	■

NOTE: "■": Yes

## TECHNICAL SPECIFICATION

Item	Parameter		
Accuracy	0.5%		
Display data update time	1s		
Signal input	Voltage	Rated value	3*230/400V 3*100V etc.
		Overload	Continuous: 1.2Vn, instantaneous: 2Vn/1min
	Current	Energy consumption	≤0.1VA
		Rated value	1A/5A
		Overload	Continuous: 1.2In, instantaneous: 10In/5s
		Energy consumption	≤0.2VA
Frequency	45~65Hz		
Communication	RS485 interface	Modbus-RTU protocol, baud rate up to 9600bps	
Power supply	Working range	AC/DC 80~270V 50/60Hz	
	Energy consumption	≤5VA	
Ambient condition	Working temperature	-10°C~55°C	
	Relative humidity	≤95%RH	
	Altitude	≤2500m	
Safety	Insulation	Signal, power supply, output terminals to case resistance≥100MΩ	
	Withstand voltage	Power supply, input and output≥2kV	
Protection level	Front IP54, Rear IP20		

## DIMENSIONS

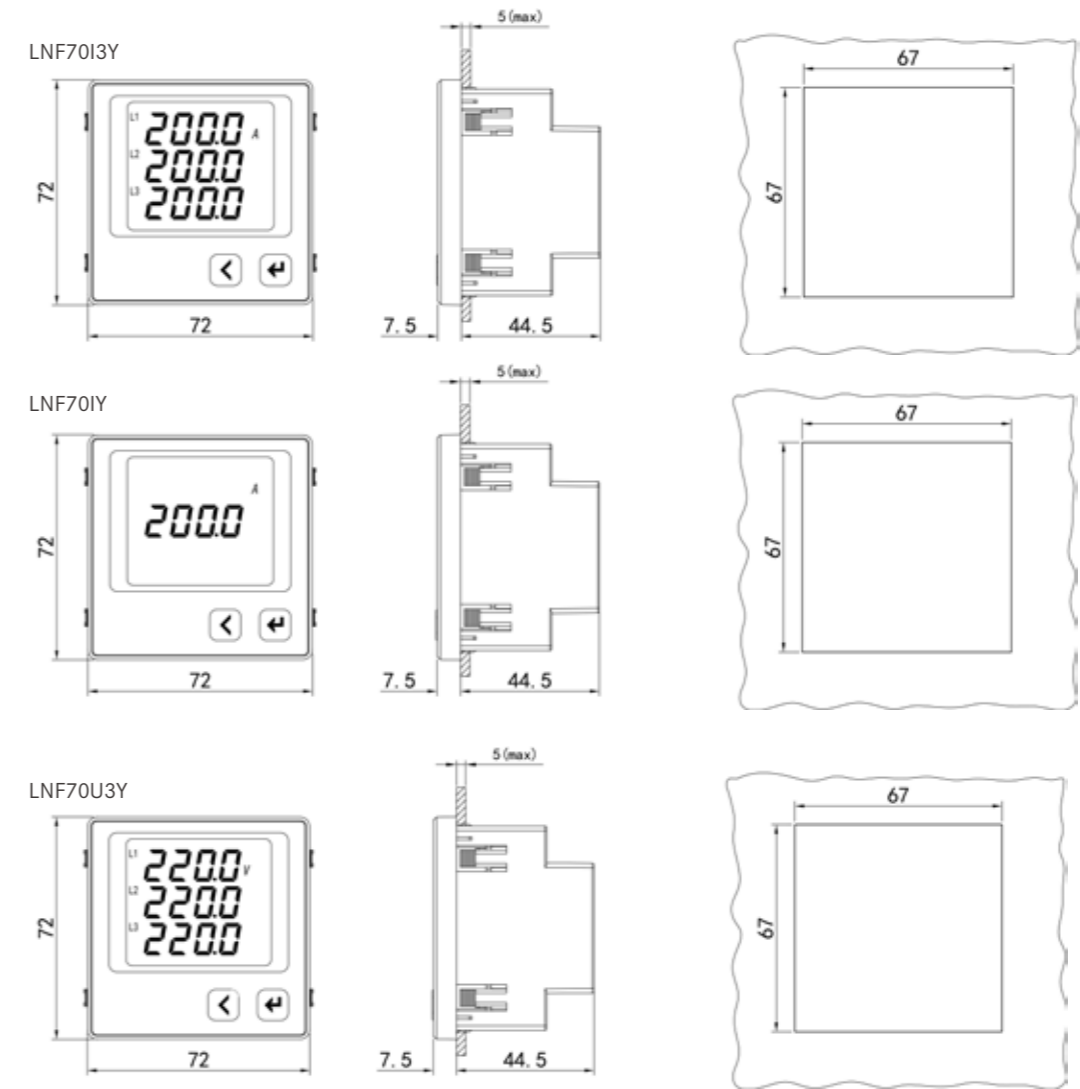

## TYPICAL WIRING

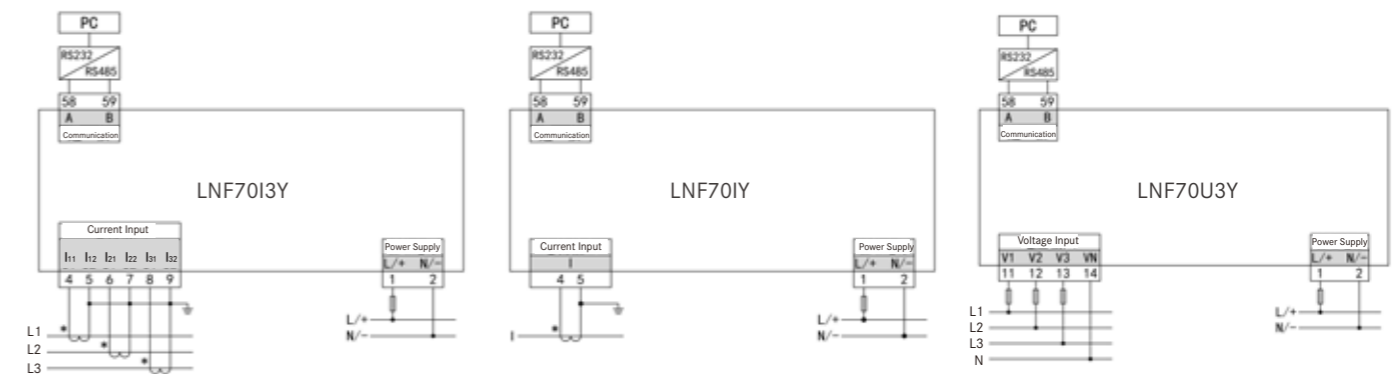



# SMART MODULE

Digital Intelligent Power Distribution Solution Provider  
<http://en.sfere-elecnova.com>



## Sfere700-TM Sfere700-TS

Distributed multi-channel temperature monitoring module



Distributed design  
 Scale flexibly  
 Up to 24 temperature measurements  
 RS485 communication interface



### APPLICATIONS



Low-voltage power distribution system



Temperature monitoring

### FUNCTION

Model	Sfere700-TM	Sfere700-TS
Type	Master module	Slave module
Temperature monitoring channel	6	6
RS485 communication interface	1-way slave station (to external) 1-way master station (to slave module)	1-way slave station

## DIMENSIONS

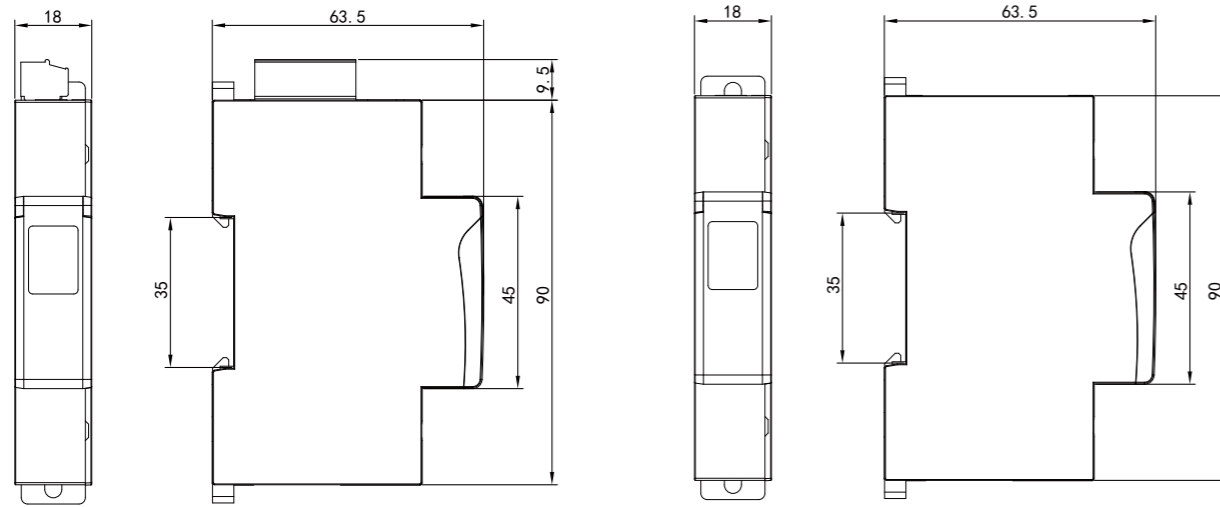

Sfere701-TM

Sfere701-TS

## TYPICAL WIRING

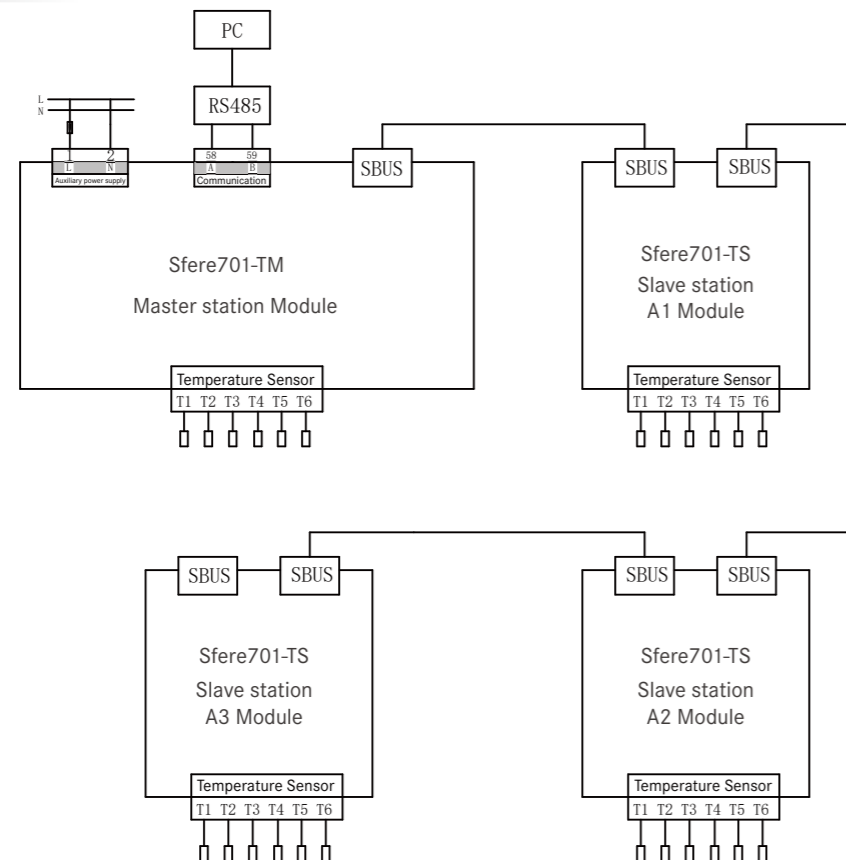

## TECHNICAL SPECIFICATION

Function	Sfere700-TM	Sfere700-TS
<b>Temperature measurement</b>		
Number	6 (Single module)	
Type	NTC 10k	
Accuracy	±1 °C	
Range	-20 ~ 140 °C	
<b>Power supply</b>		
Voltage Range	AC/DC 80 ~ 270V, 50/60Hz	SBUS Power
Consumption	≤ 5VA	
<b>Communication</b>		
Interface	RS485	
Protocol	Modbus-RTU, 4800-115200bps	
Isolation	4000V AC	
<b>Ambient condition</b>		
Operating temperature	-20°C ~ 70°C	
Relative humidity	≤ 95%RH, Non condensing	
Altitude	≤ 2500m	
IP Degree	IP20	
Withstand	IEC 61010-1	
<b>EMC</b>		
Electrostatic discharge immunity	IEC 61000-4-2- Level III	
Radio frequency electromagnetic field radiation immunity	IEC 61000-4-3- Level III	
Electrical fast transient immunity	IEC 61000-4-4- Level III	
Impact (surge) immunity	IEC 61000-4-5- Level III	
Immunity to conducted interference induced by RF field	IEC 61000-4-6- Level III	
Power frequency magnetic field immunity	IEC 61000-4-8- Level III	
Immunity to voltage sags and short interruptions	IEC 61000-4-11- Level III	

# Sfere700-DI3

## Switching monitoring module



Easy to install  
RS485 communication interface  
Compact design



### APPLICATIONS



Low-voltage power  
distribution system



Temperature  
monitoring

### DIMENSIONS

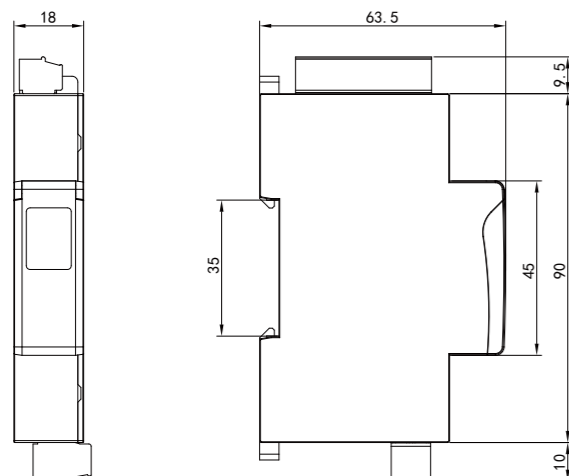

### TYPICAL WIRING

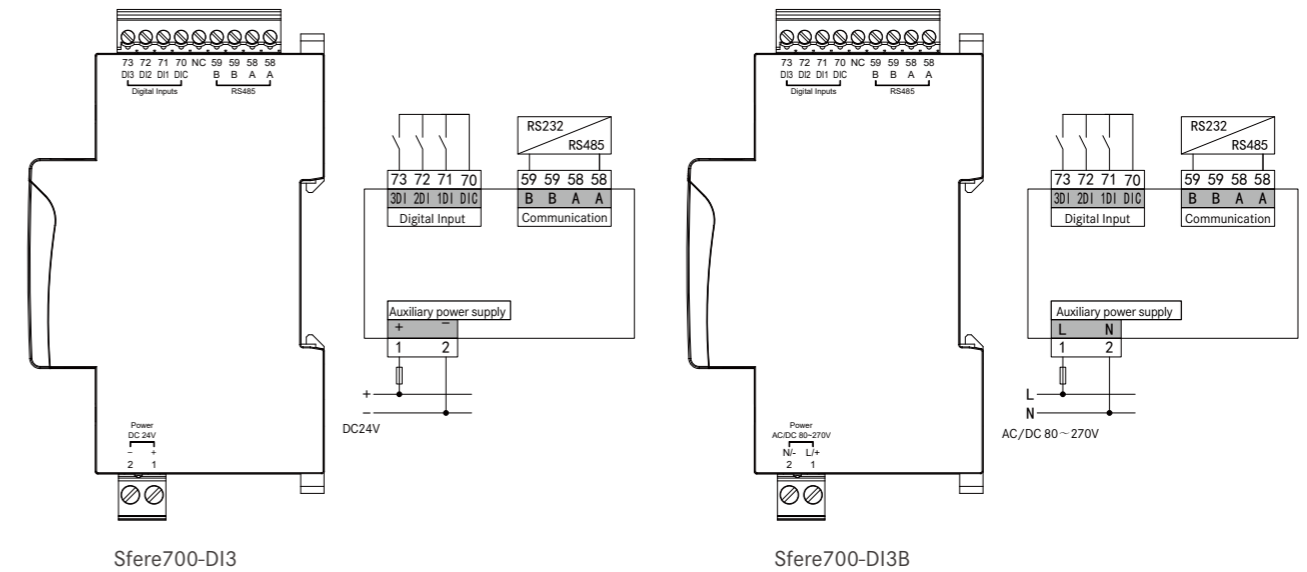

### TECHNICAL SPECIFICATION

Digital input	
Number	3
Input type	Dry contact
Insulation	2000 V AC
Scan time	10 ms
Filter time	30 ms
Communication	
Interface	RS485
Protocol	Modbus-RTU, up to 19200bps
Insulation	2000 V AC
Power supply	
Rated range	Sfere700-DI3: DC24V $\pm$ 20%; Sfere700-DI3B: AC/DC 80 ~ 270V
Consumption	$\leq$ 0.5W
Ambient condition	
Operating temperature	-25°C ~ 70°C
Relative humidity	$\leq$ 95%RH
Altitude	$\leq$ 2000m
IP Degree	IP20
EMC	Better than level III

# BUSWAY TEMPERATURE MONITORING SYSTEM

Digital Intelligent Power Distribution Solution Provider  
<http://en.sfere-elecnova.com>



## Sfere702

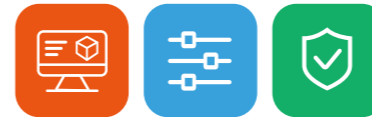



Specially designed for busway temperature monitoring  
RS-485 & RJ45 Ethernet communication interfaces  
Safe and reliable



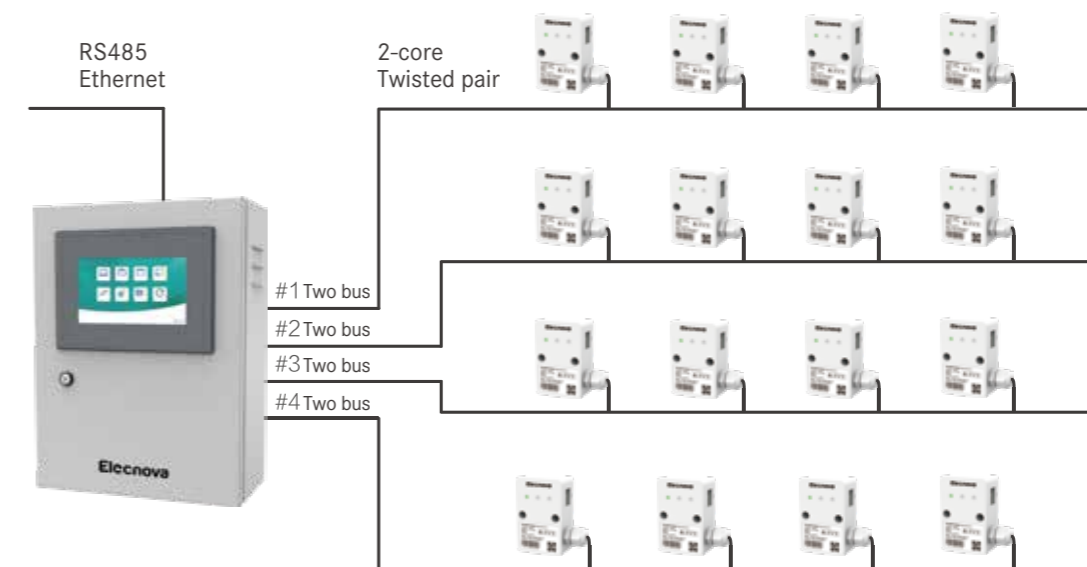

### SYSTEM STRUCTURE

Sfere702 busway temperature monitoring system is composed of monitoring host, temperature & humidity acquisition module and temperature sensor. The system adopts DC24V power supply, which makes it safe and reliable. The monitoring host is equipped with RS-485 and RJ45 Ethernet interfaces, providing Modbus-RTU and Modbus-TCP communication protocols externally, which can be connected to other standard systems.



Items	Sfere702-B	Sfere702-BM
<b>Bus type</b>	Non-polarity two bus	Non-polarity two bus
<b>Monitoring capacity (accessible module)</b>	Sfere702-B-2: two bus lines 2 * 128 = 256 modules Sfere702-B-4: four bus lines 4 * 128 = 512 modules	Sfere702-B-2: four bus lines 2 * 128 = 256 modules
<b>Outline dimension</b>	 420(W) X 560(H) X 195(D) 587(H) (including waterproof adapter)	 298(W) X 398(H) X 155(D) 425(H) (including waterproof adapter)
<b>External communication interface</b>	1 RS232, 1 RS485, 1 RJ45 Ethernet (2 more can be added)	1 RS485, 1 Ethernet
<b>Display mode</b>	10-inch HMI	7-inch HMI
<b>Input and output</b>	Four relay outputs	Two relay outputs
<b>Sound and light alarm</b>	High decibel buzzer LED indicator	Built in buzzer
<b>Backup power supply</b>	Two emergency batteries, 12V/12AH battery	-
<b>Printing function</b>	Micro printer	-
<b>Installation method</b>	Wall mounted	Wall mounted

Items	Sfere702-TC	Sfere702-TD
<b>Monitoring position</b>	Busway junction point	Busway shell
<b>Power supply</b>	Bus power supply DC24V	
<b>Bus type</b>	Non-polarity two bus	
<b>Outline dimension</b>		
<b>Temperature measurement channel</b>	1 channel of temperature measurement/ 1 channel of humidity measurement	4 channel of temperature measurement/ 1 channel of humidity measurement
<b>Temperature probe</b>	Non-contact infrared type	Round hole contact type
<b>Display mode</b>	-	-
<b>Outline dimension</b>	72*48*28	72*48*28

NOTE: "-" : No



# MOTOR PROTECTION CONTROLLER

Digital Intelligent Power Distribution Solution Provider

<http://en.sfere-elecnova.com>



# WDH-31-200



Modbus Interface  
Protection (9 Types)  
Analog Output



## APPLICATIONS

M

Motor  
Control Centre

## MODEL

WDH-31-203K -

Current Code	Optional Code	Installation Mode	Cable Length for CT
2A 100A	L: Residual current	Y: Integrated	1m
6.3A 200A	M2: Analog output	F: Split	3m
30A 5A(Secondary current)			

Current	Rated Current for Motor	SHI-I CT Code
2A	1A~2A	SHI01-I, Φ 20mm
6.3A	2A~6.3A	SHI30-I, Φ 20mm
30A	6.3A~30A	
100A	50A~100A	SHI200-I, Φ 20mm
200A	100A~200A	SHI300-I, Φ 30mm
5A	>200A	SHI30-I, Φ 20mm +3pcs of external CT XA:5A

## OPTIONAL CT



Model	THREE-PHASE CT		EXTERNAL CT	RESIDUAL CURRENT CT	
	SHI30-1 /SHI200-1	SHI300-1	SHI-ZT40	SHI-ZT30	SHI-ZT100
Diameter(mm)	20	30	42x30	31	100
Dimension(mm)	93x45x96	185x36x72	75x44x102	75x44x98	185x44x190

## DIMENSIONS

Split Installation (Cut-out Size: 94x46mm)

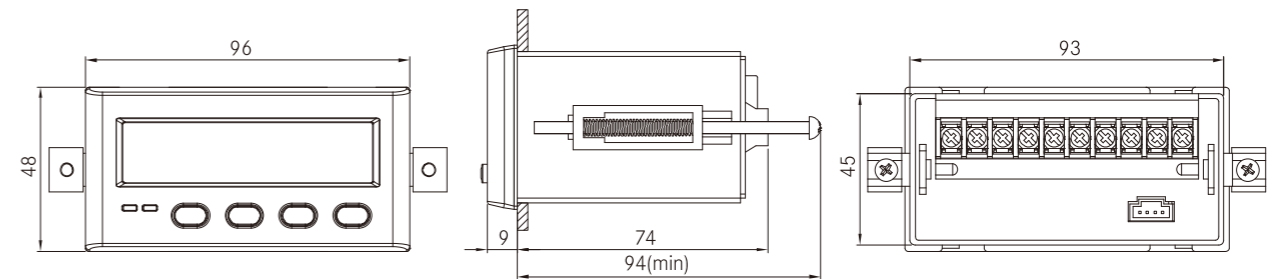

Integrated Installation

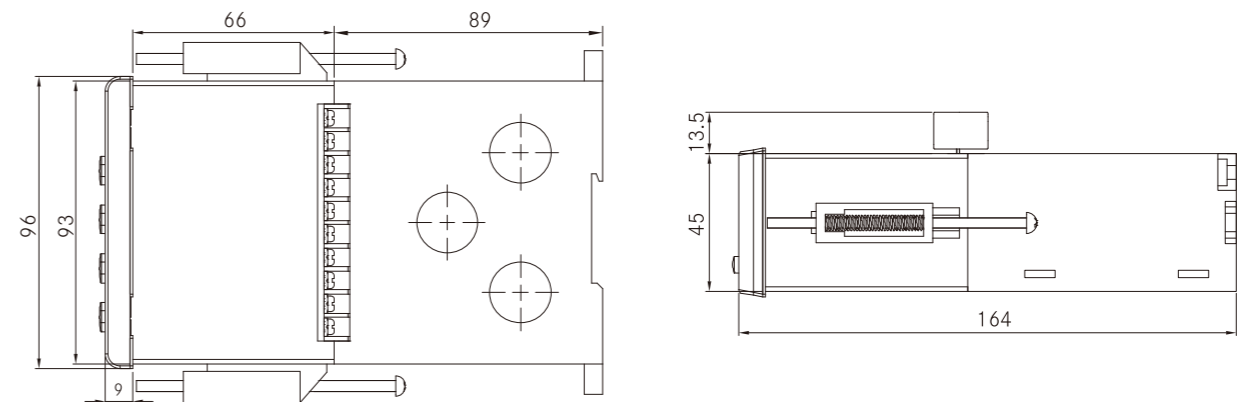

## FUNCTION

<b>Measurement function</b>	Three-phase current	■
	Current unbalance	■
	Thermal capacity	■
	Residual current (leakage) 50mA~5000mA	□
	Single-phase voltage	■
<b>Relay output</b>	Control & Signal relay	■
<b>Analog output</b>	1 channel of DC 4-20mA analog output	□
<b>Maintenance information</b>	Alarm information/fault record	■
<b>Display mode</b>	LED display (operate/fault indicate)	■
	LCD display (operation status, fault information, parameter setting, etc)	■
<b>Installation mode</b>	Optional for integrated or split installation	Panel mounting, (94*46)mm, integrated type can be Mounted on 35mm DIN-rail
<b>Protection function</b>	Overload inverse time protection	■
	Start acceleration timeout protection	■
	Locked rotor (starting overcurrent) protection	■
	Blocking (operation overcurrent) protection	■
	Leakage protection	■
	Current unbalance/phase failure protection	■
	Overvoltage protection	■
	Undervoltage protection	■
	Residual current (leakage) (50~5000) mA	□
<b>Control protection</b>	Protection mode	■
<b>Communication function</b>	Modbus-RTU	■

NOTE: "■": Yes "□": Optional

## TECHNICAL SPECIFICATION

<b>System operating parameter</b>	Motor rated voltage	AC400V, 50Hz
	Motor rated current	0.1A~800A
	Insulation resistance	> 100MΩ
<b>Controller auxiliary power</b>	Working range	AC/DC 80V~270V
<b>Ambient condition</b>	Operating temperature	-20 C ~ 60 C
	Relative humidity	< 93%RH
	Storage temperature	-40 C ~ 70 C
	Protection degree (Panel)	IP64
Notice	No explosive medium, metal corroding gas and conducting medium at site	
<b>Protection action accuracy</b>	Current/voltage start value	±2% of the set value
	Accumulated value of thermal capacity	±1% of the set value
<b>Action delayed time</b>	Action delayed time set value < 2s	±100mS
	Action delayed time set value ≥ 2s	±5%
<b>Relay output</b>	Control relay output contact capacity	AC250V/5A
	Signal relay output contact capacity	AC250V/3A, DC30V/3A
	Service time of relay output	100000 times
<b>EMC</b>	Electrostatic discharge test	Severe degree: Class III
	Electrical fast transient burst immunity test (EF)	Severe degree: Class III
	Surge	Severe degree: Class III
	Oscillatory waves immunity	Severe degree: Class III
	Radiated radio-frequency electromagnetic field immunity(RF-EMS)	Severe degree: Class III
	Radio frequency radiation immunity	Severe degree: Class III
	Power frequency immunity	Severe degree: Class A
	CE limit test	150kHz~30MHz
	Conducted emission limit test	30MHz~1000MHz
	<b>Withstand voltage</b>	Between power supply and input
Between power supply and output		AC2kV/1 min
Between input and output		AC1kV/1 min

**TYPICAL WIRING**

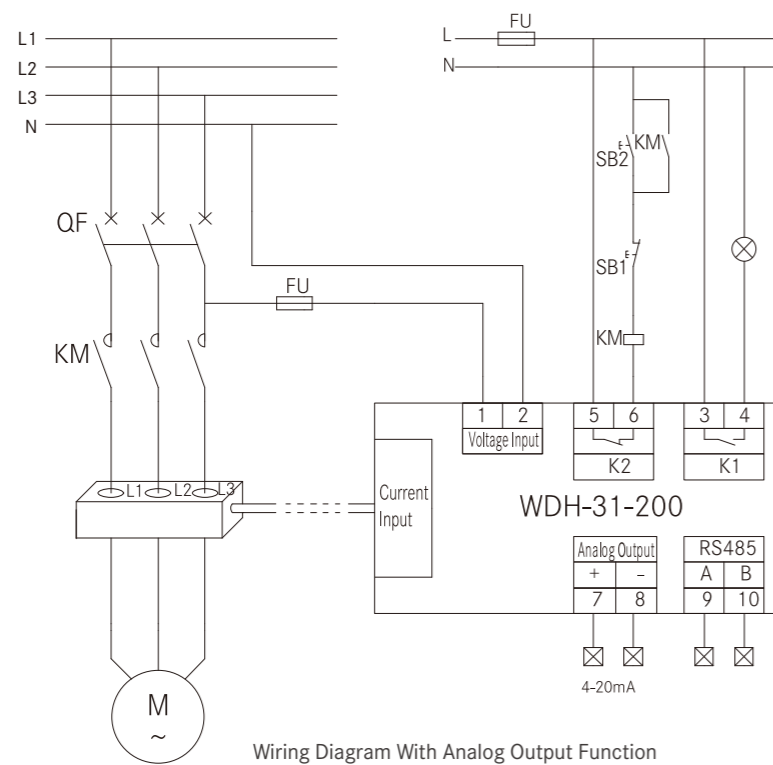
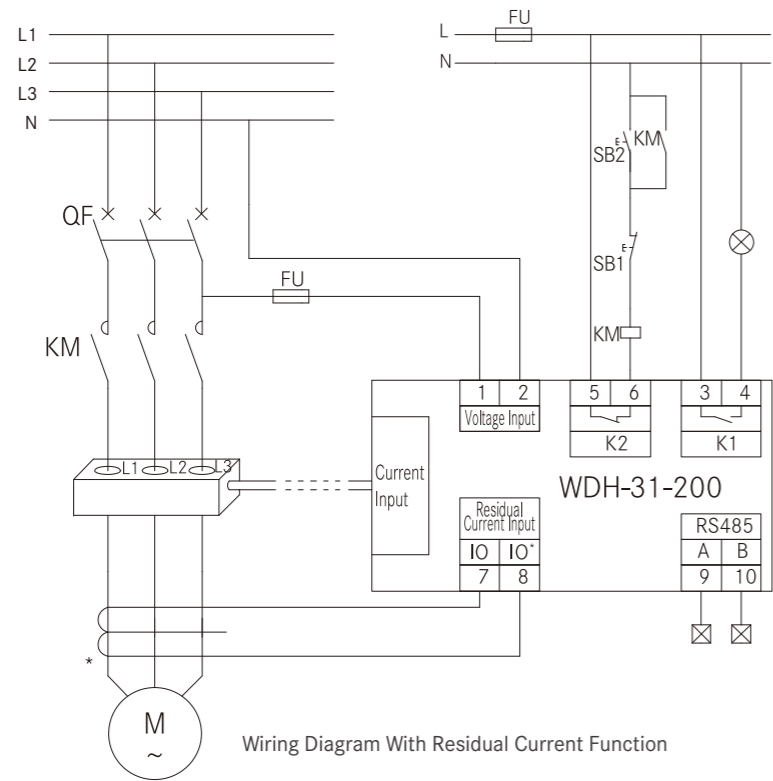

# WDH-31-530



- 16 protection functions
- 5 programmable digital inputs
- 4 programmable relay outputs
- Intelligent Human-machine interface
- SOE record
- FSTN/TFT LCD display module optional

**MODEL**

WDH-31-53

Communication protocol	Control mode	Current specification of protection controller	Main circuit voltage	Optional functions
1(1 Modbus-RTU/Display integration)	A: Direct start	5A	AC400V	V: Anti voltage sag/ Low voltage restart
2(1 Profibus-DP+1 Modbus-RTU)	B: Bi-directional start	25A	AC660V	
3(1 Modbus-RTU)	C: Double speed start	100A	AC100V	
4(2 Modbus-RTU)	D: Resistor divider start	300A		
7(1 Modbus-RTU/1 Modbus-TCP/IP)	E: Y/ Δ start	500A		
9(1 Modbus-RTU/1 Profinet)	H: Autotransformer start	800A		
	K: Protection mode			
	R: Start with soft-starter			
	P: Start with inverter			

Adjustable range	Configurable Motor Power	Diameter
0.2A~5A	5A	Φ10.5mm
5A~25A	25A	Φ10.5mm
25A~100A	100A	Φ18mm
>100A	5A	Φ10.5mm+3pcs of external CT XA:5A



## FUNCTION

<b>Measurement function</b>	Three-phase current	■
	Current unbalance	■
	Thermal capacity	■
	Residual current (grounding) 0.3Ie~8.0Ie	■
	Residual current (leakage) 50mA~5000mA	■
	Three-phase voltage	■
	Positive & negative sequence current	■
	Power and energy	■
<b>Real-time clock</b>	Year, month, day, hour, minute, second	■
<b>Digital input</b>	Dry contact (built-in DC 24V)	5 channels
<b>Relay output</b>	Control relay	3 channels
	Signal relay	1 channels
<b>Analog output</b>	1 channel of DC 4-20mA analog output, parameter programmable	■
<b>Maintenance information</b>	Alarm information/fault record	■
	Start/stop record, switch status changing record	■
	Operation times, total operation time and total shutdown time	■
<b>Display mode</b>	LED display (operate/fault indicate)	■
	LCD display (operation status, fault information, parameter setting, etc)	■
<b>Installation mode</b>	Controller main body	Mounted on 35mm DIN-rail
	Display module	Panel mounting, (92*55)mm
<b>Communication function (Select any one)</b>	1 (1 Modbus-RTU/Display integration)	□
	2 (1 Profibus-DP+ 1 Modbus-RTU)	□
	3 (1 Modbus-RTU)	□
	4 (2 Modbus-RTU)	□
	7 (1 Modbus-RTU/1 Modbus-TCP/IP)	□
	9 (1 Modbus-RTU/1 Profinet)	□

NOTE: ■: Yes □: Optional

<b>Protection function</b>	Overload inverse time protection	■
	Start acceleration timeout protection	■
	Locked rotor (starting overcurrent) protection	■
	Blocking (operation overcurrent) protection	■
	Leakage protection	■
	Voltage/current unbalance/phase failure protection	■
	Underload/undercurrent protection	■
	Overvoltage protection	■
	Undervoltage protection	■
	Phase sequence protection	■
	PT disconnection protection	■
	Residual current (grounding) (0.3~8.0) Ie protection mode	■
	Residual current (leakage)(50~5000)mA	■
	External fault protection (process interlocking)	■
	tE time protection (increased safety motor)	□
<b>Control protection</b>	Protection mode	■
	Direct start	■
	Bi-directional start	■
	Double speed start	■
	Y/ Δstart	■
	Resistor divider start	■
	Autotransformer start	■
	Start with soft-starter	■
	Start with inverter	■
	Anti voltage sag(low voltage restart)	□
Power-on automatic start	■	

## FUNCTION

<b>System operating parameter</b>	Motor rated voltage	AC400V, 50Hz
	Motor rated current	0.1A~800A
	Insulation resistance	> 100MΩ
<b>Controller auxiliary power</b>	Working range	AC/DC 80V~270V
<b>Ambient condition</b>	Operating temperature	-20℃~60℃
	Relative humidity	≤93%RH
	Protection degree (Panel)	IP64
	Notice	No explosive medium, metal corroding gas and conducting medium at site
<b>Protection action accuracy</b>	Current/voltage start value	±2% of the set value
	Accumulated value of thermal capacity	±1% of the set value
<b>Action delayed time</b>	Action delayed time set value < 2s	±100ms
	Action delayed time set value ≥ 2s	±5%
<b>Relay output</b>	Control relay output contact capacity	AC250V/5A
	Signal relay output contact capacity	AC250V/3A, DC30V/3A
	Service time of relay output	100000 times
<b>EMC</b>	Electrostatic discharge test	Severe degree: Class III
	Electrical fast transient burst immunity test (EF)	Severe degree: Class III
	Surge	Severe degree: Class III
	Oscillatory waves immunity	Severe degree: Class III
	Radiated radio-frequency electromagnetic field immunity (RF-EMS)	Severe degree: Class III
	Radio frequency radiation immunity	Severe degree: Class III
	Power frequency immunity	Severe degree: Class A
	CE limit test	150kHz~30MHz
Conducted emission limit test	30MHz~1000MHz	
<b>Withstand voltage</b>	Between power supply and input	AC2kV/1 min
	Between power supply and output	AC2kV/1 min
	Between input and output	AC1kV/1 min

NOTE: ■: Yes □: Optional

## DIMENSIONS

Controller installation (5A/25A perforated connection)

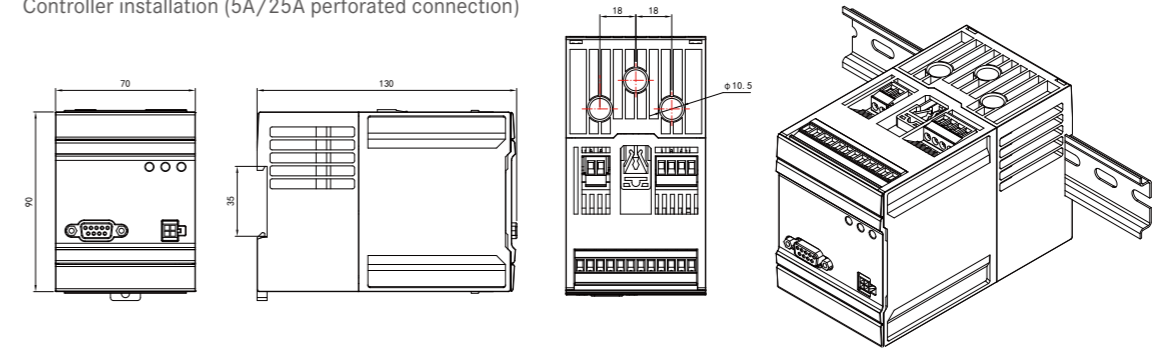

Controller installation (100A perforated connection)

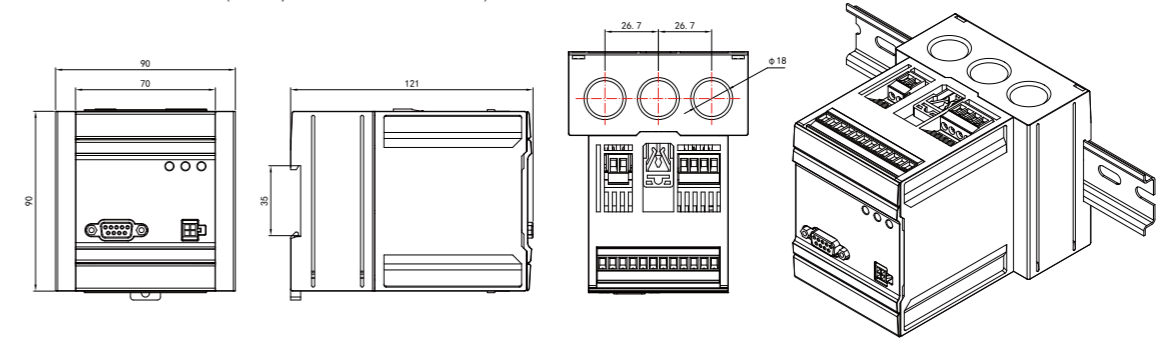

Display panel installation

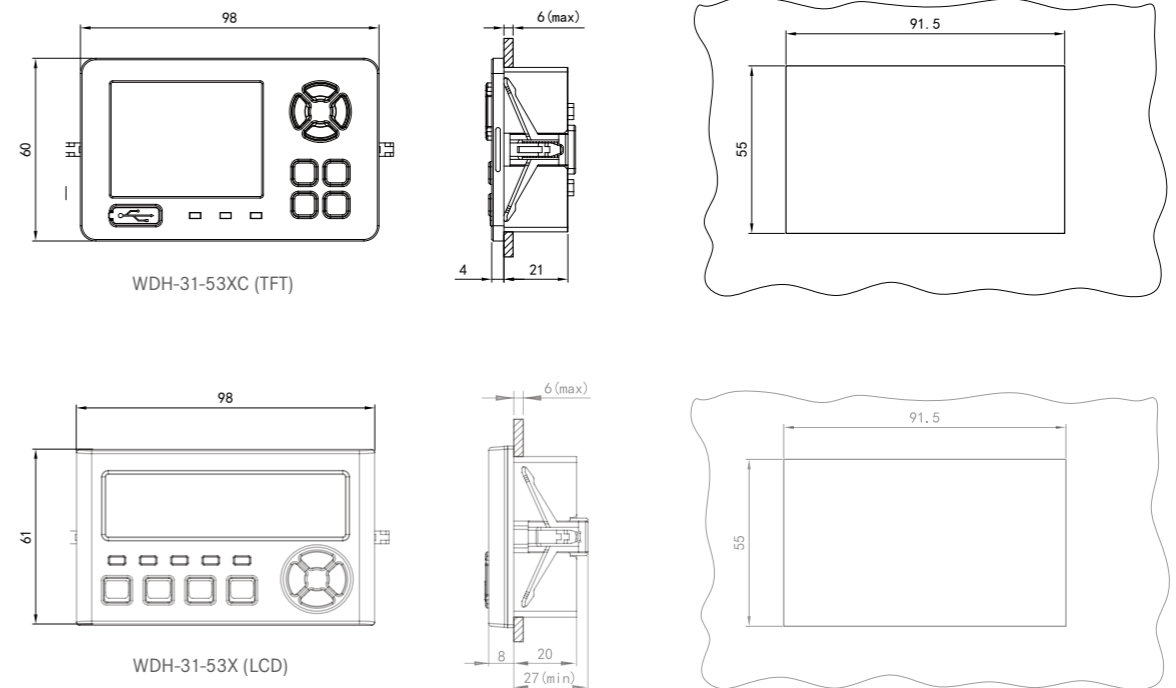

Thermal relay

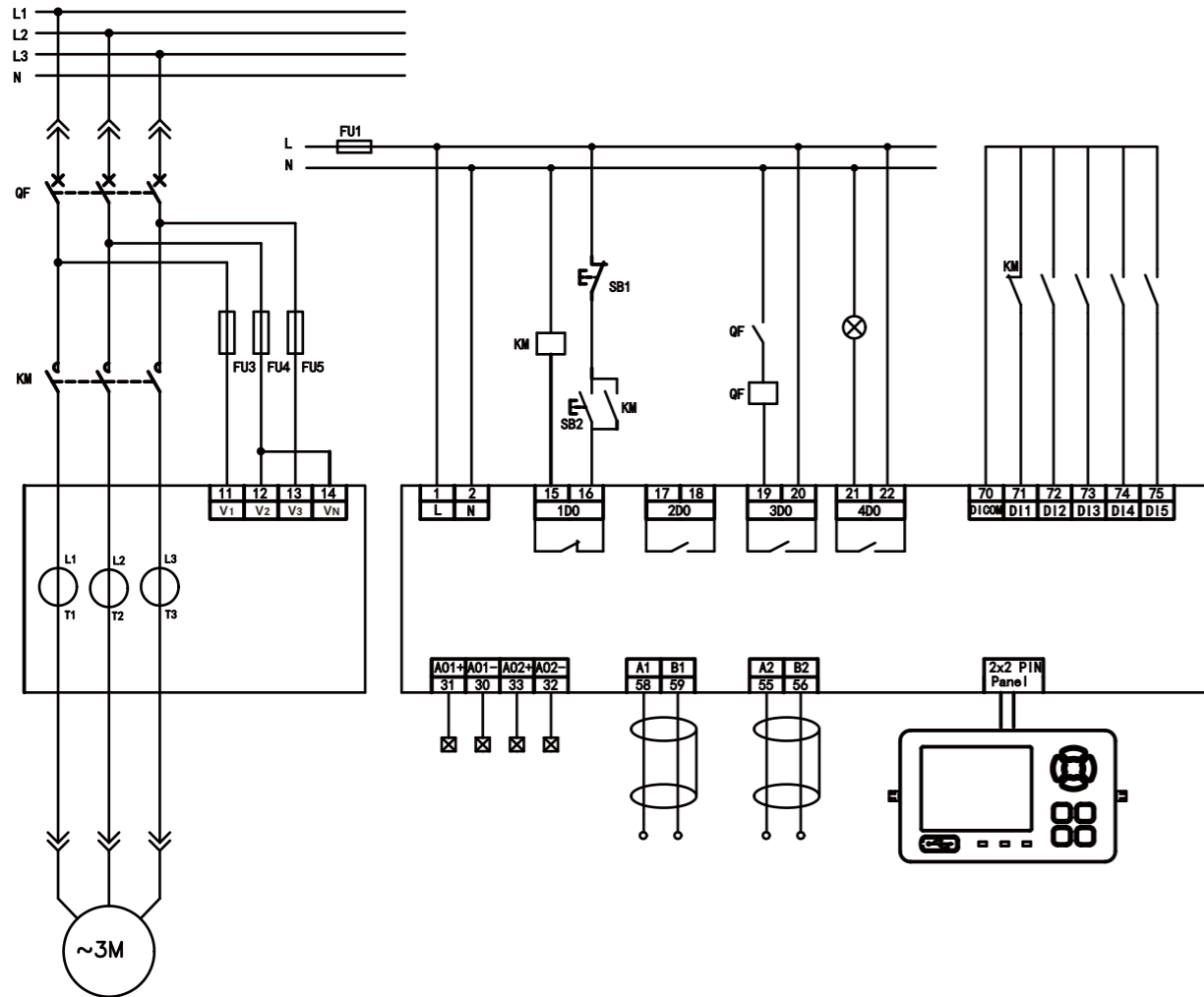

- Under the thermal relay mode, WDH does not participate in the start and stop operation of motor (DI terminal and panel control are invalid).
- The start/stop running of the motor must implement by the Start/Stop external button
  - As drawing shown, press the start button SB2, motor start, press stop button SB1, motor stop
  - Protection trip relay 1DO is NC contract, when fault was detected, 1DO open, contactor(KM) off, motor will stop
  - After fault reset, 1DO closed, allow the motor start again.

Direct start

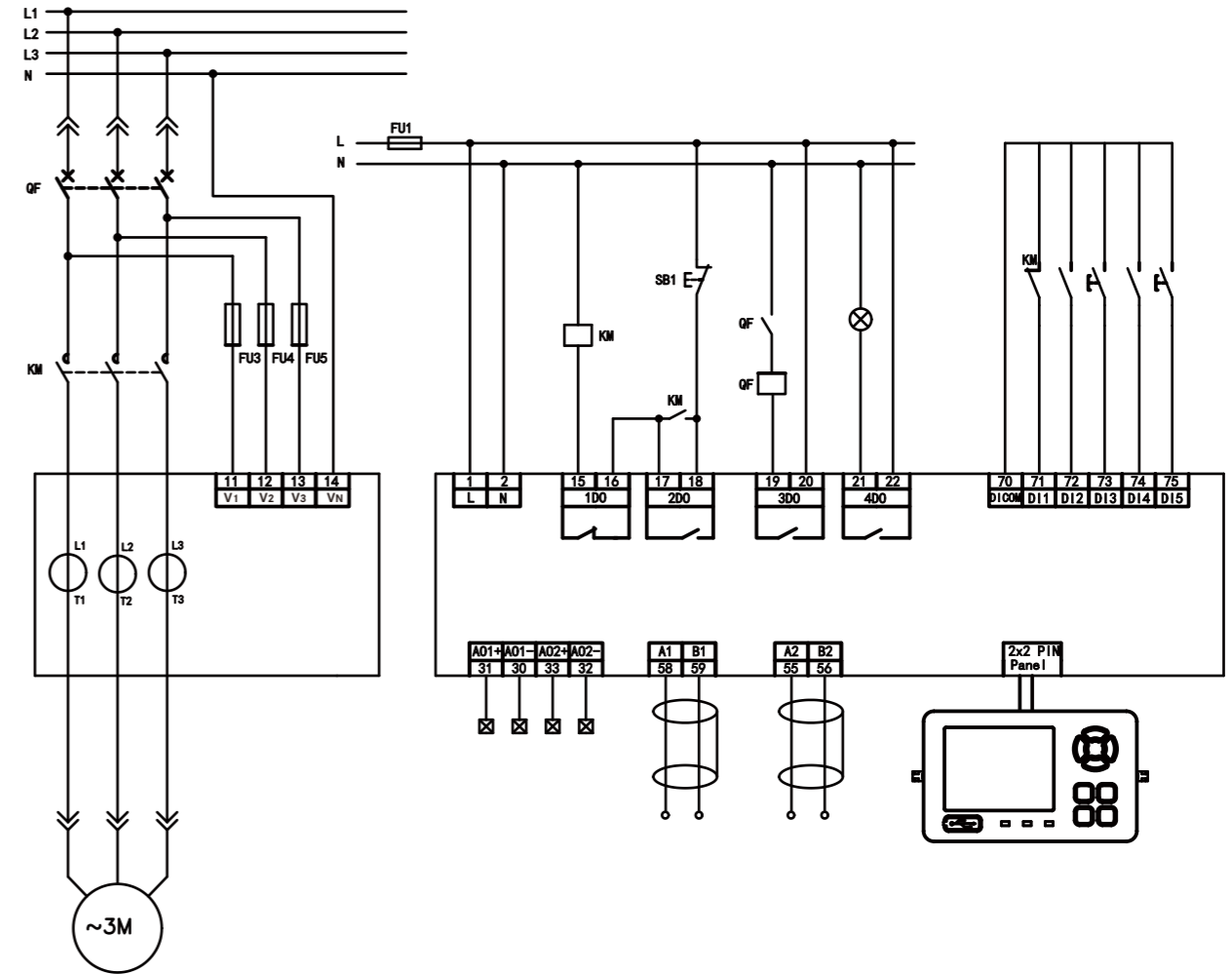

- Under the direct start mode, WDH controls the motor start/stop by relay 1DO(NC)/2DO(NO).
- As drawing shown, when the controller receive the start command(such as 3DI terminal or display interface), 2DO closed(pulse), contactor(KM) power on, motor start
- When the controller receives the stop command(such as 5DI terminal or display interface), 1DO open(pulse), contractor KM power off, motor stop.
- When faults were detected, 1DO open(level), contractor KM power off, motor stop.
- After reset, 1DO closed, controller allows the motor restart again.

# WDH-31-580



Modbus Interface  
Protection (21 Types)  
Analog Output  
Temperature  
Harmonics



## FUNCTION

### Motor Protection

- Start timeout
- Stall
- Locked rotor
- Overload
- Under load
- Current unbalance
- Over voltage
- Low voltage
- Residual current
- Phase loss
- Phase-sequence
- Under power

### Measuring

- 3-phase voltage
- 3-phase current
- Residual current
- Energy
- Harmonics

### Communication

- Profibus-DP
- Modbus-RTU
- Ethernet Modbus/TCP

## MODEL

WDH-31-58

Communication protocol	Control Mode	Current Specification of Protection Controller	Main Circuit Voltage	Digital Input Type	Optional Functions	Additional Components
2:1 Profibus-DP protocol +1Modbus-RTU protocol	A: Direct start B: Bi-directional start	1:5A 2:25A	1:AC 400V 2:AC 660V	1: Internal DC24V power supply	R: Insulation resistance monitoring	D: Switching module-DC24V DA: Switching module-AC220V
3: 2 Modbus-RTU protocol	C: Double speed start D: Resistor divider start	3:100A 4:250A	3:AC 100V	2: External AC220V power supply	V: Anti voltage sag/under voltage restart	X: Display module
7:1 Modbus-RTU protocol +1 Ethernet Modbus/TCP protocol	E: Y/Δ start H: Autotransformer start K: Protection mode R: Start with soft-starter P: Start with inverter	5:500A 6:800A				

Code	Adjustable Range	Configurable Motor Power (400V system)	Measurement Module	Diameter
1	0.2A~5A	0.13kW~2kW	WM1/05	φ 18mm
2	5A~25A	2kW~11kW	WM1/25	φ 18mm
3	25A~100A	11kW~55kW	WM1/100	φ 18mm
4	100A~250A	45kW~115kW	WM1/250	Copper Bar
5	200A~500A	90kW~280kW (Configured with 3pcs of external CT 500A:5A)	WM1/05	φ 18mm
6	500A~800A	280kW~400kW (Configured with 3pcs of external CT 800A:5A)	WM1/05	φ 18mm

## OPTIONAL CT



### External CT

Model	SHI-ZT40	SHIZT60
Diameter(mm)	42x30	32x62.5
Dimension(mm)	75x44x102	100x50x112

## DIMENSIONS

Measurement Module  
WM1: 5A, 25A, 100A(Perforation connection mode)

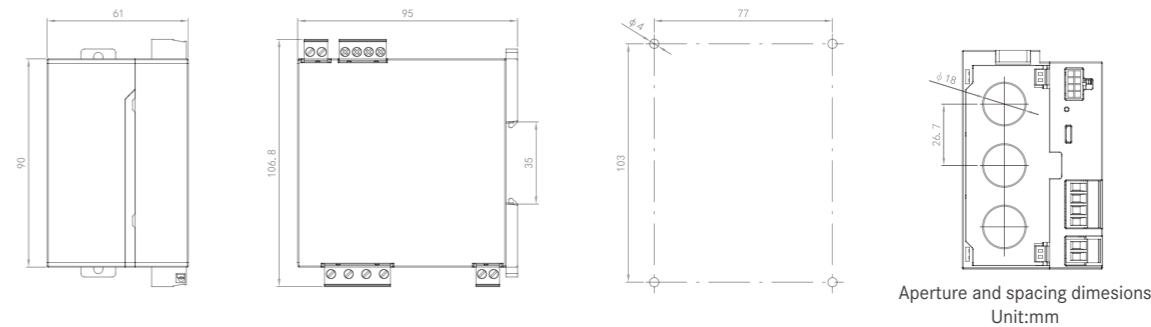

WM2: 250A (Copper bar connection mode)

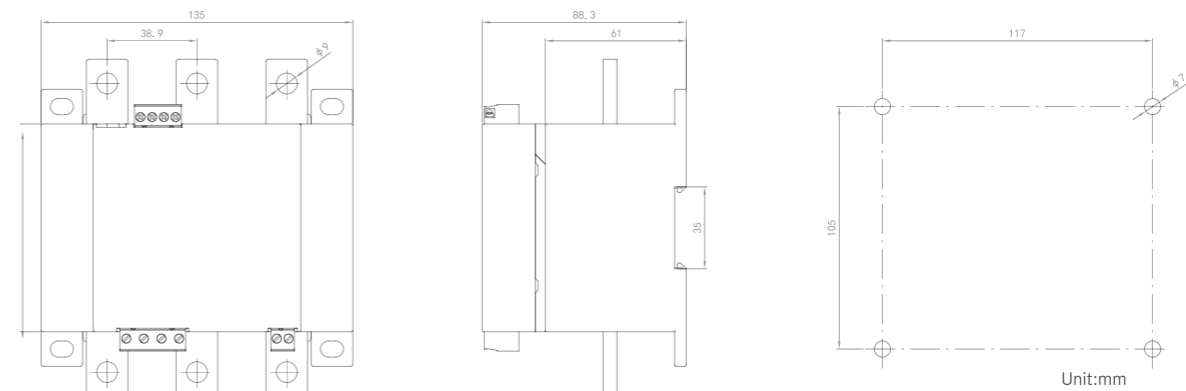

Main Control

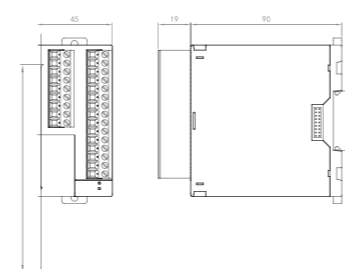

Switching

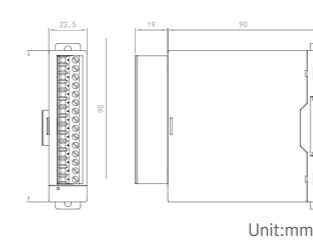

Display

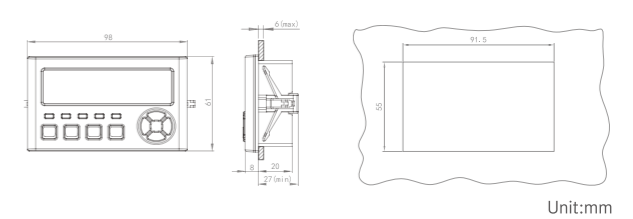

## FUNCTION

<b>Measurement function</b>	Three-phase current	■
	Current unbalance	■
	Thermal capacity	■
	Residual current (grounding) 0.3Ie~8.0Ie	■
	Residual current (leakage) 50mA~5000mA	■
	Three-phase voltage	■
	Frequency	■
	Power and energy	■
	Up to 31st harmonics	■
	Thermistor (10kΩ)	■
	Thermal resistance (PT100)	■
	Insulation resistance (200MΩ)	□
	<b>Real-time clock</b>	Year, month, day, hour, minute, second
<b>Digital input (either-or)</b>	Dry contact (built-in DC 24V)	5 channels 12 channels optional
	Wet contact (external AC220V)	5 channels 12 channels optional
<b>Relay output</b>	Control & Signal relay	4 channels 8 channels optional
<b>Analog output</b>	2 channel of DC 4-20mA analog output, parameter programmable	■
<b>Maintenance information</b>	Fault recorder	■
	Alarm information / fault record	■
	Start/stop record, switch status changing record	■
	Operation times, total operation time and total shutdown time	■
<b>Communication function (either-or)</b>	1 Profibus-DP + 1 Modbus-RTU	□
	2 Modbus-RTU	□
	1 Modbus-RTU+1 Ethernet Modbus/TCP	□
<b>Display mode</b>	LED display (operate / fault indicate)	■
	LCD display (operation status, fault information, parameter setting, etc)	□

NOTE: "■": Yes "□": Optional

<b>Installation mode</b>	Main control module	Mounted on 35mm DIN-rail	
	Measurement module	Mounted on 35mm DIN-rail	
	Switch module	Mounted on 35mm DIN-rail	
<b>Protection function</b>	Display module	Panel mounting, (92*55)mm	
	Overload inverse time protection	■	
	Start acceleration timeout protection	■	
	Locked rotor (starting overcurrent) protection	■	
	Blocking (operation overcurrent) protection	■	
	Leakage protection	■	
	Voltage unbalance/current unbalance/phase failure protection	■	
	Underload/undercurrent protection	■	
	Underload / undercurrent protection	■	
	Overvoltage protection	■	
	Undervoltage protection	■	
	Phase sequence protection	■	
	PT disconnection protection	■	
	Residual current (grounding) (0.3~8.0)Ie protection mode	■	
	Residual current (leakage) (50~5000)mA	■	
	External fault protection (process interlocking)	■	
	Temperature protection	■	
	tE time protection (increased safety motor)	□	
	<b>Control protection</b>	Protection mode	■
		Direct start	■
		Bi-directional start	■
Double speed start		■	
Y/ Δstart		■	
Resistor divider start		■	
Autotransformer start		■	
Start with soft-starter		■	
Start with inverter		■	
Anti voltage sag (low voltage restart)		□	
Power-on automatic start	■		

## FUNCTION

<b>System operating parameter</b>	Motor rated voltage	AC400V, 50Hz
	Motor rated current	0.1A~800A
	Insulation resistance	> 100MΩ
<b>Controller auxiliary power</b>	Working range	AC/DC 80V~270V
<b>Ambient condition</b>	Operating temperature	-20 C ~ 60 C
	Relative humidity	≤ 93%RH
	Storage temperature	-40 C ~ 70 C
	Protection degree (Panel)	IP64
	Notice	No explosive medium, metal corroding gas and conducting medium at site
<b>Withstand voltage</b>	Between power supply and input	AC2kV/1 min
	Between power supply and output	AC2kV/1 min
	Between input and output	AC1kV/1 min
<b>Protection action accuracy</b>	Current/voltage start value	±2% of the set value
	Accumulated value of thermal capacity	±1% of the set value
<b>Action delayed time</b>	Action delayed time set value < 2s	±100mS
	Action delayed time set value ≥ 2s	±5%
<b>Relay output</b>	Control relay output contact capacity	AC250V/5A
	Signal relay output contact capacity	AC250V/3A, DC30V/3A
	Service time of relay output	100000 times
<b>EMC</b>	Electrostatic discharge test	Severe degree: Class III
	Electrical fast transient burst immunity test (EF)	Severe degree: Class III
	Surge immunity	Severe degree: Class III
	Oscillatory waves immunity	Severe degree: Class III
	Radiated radio-frequency electrom agnetic field immunity(RF -EMS )	Severe degree: Class III
	Radio frequency radiation immunity	Severe degree: Class III
	Power frequency immunity	Severe degree: Class A
	CE limit test	150kHz~30MHz
Conducted emission limit test	30MHz~1000MHz	

NOTE: "■": Yes "□": Optional

## TYPICAL WIRING

Typical Wiring Diagram for Direct Start  
(with input/output)

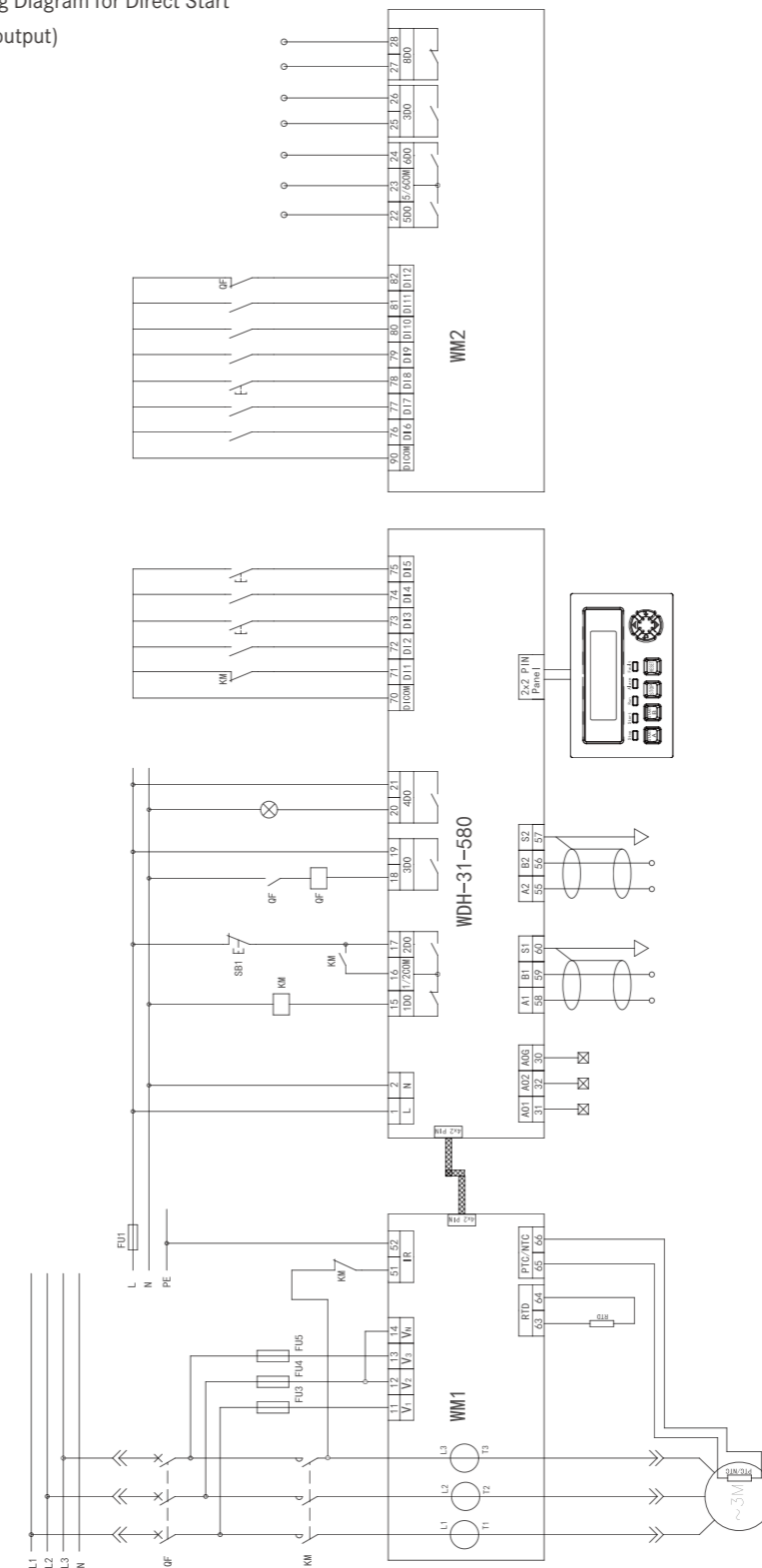

- Under the direct start mode, WDH-31-580 controls the motor start/stop by relay 1DO (NC)/2DO(NO).
- As drawing shown, when the controller receive the start command (such as 3DI terminal or display interface), 2DO closed(pulse), contactor(kM) power on, motor start.
- When the controller receives the stop command(sunch as 5DI terminal or display interface),1DO open(pulse), contractor KM power off, motor stop.
- When faults were detected, 1DO open(level), contractor KM power off, motor stop.
- After reset, 1DO closed, controller allows the motor restart again.

## TYPICAL WIRING

Typical Wiring Diagram for Bi-directional Start  
(with input/ output)

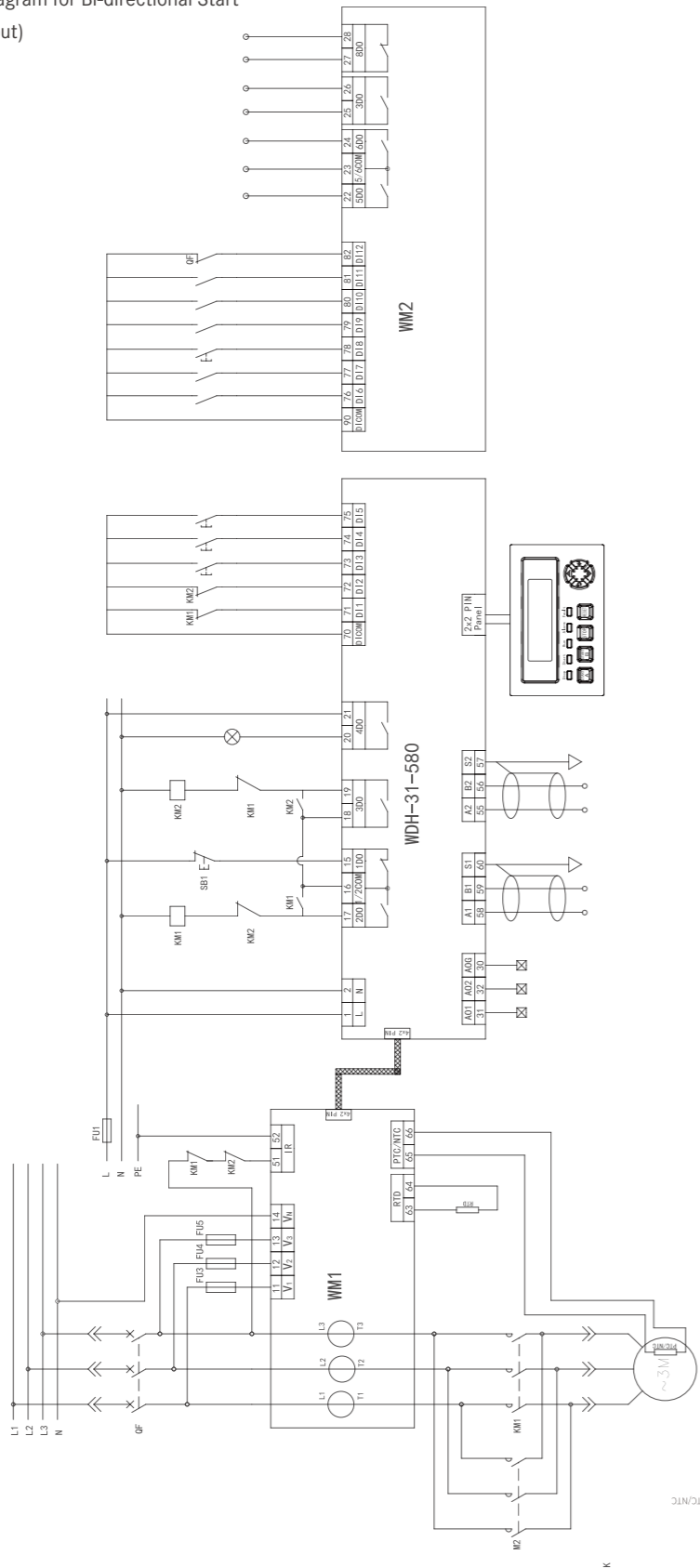

-In the bi-directional mode (forward/reverse rotation, WDH-31-580 controls the motor forward rotation start/stop by relay 1DO(NC) /2DO(NO) and by relay 1DO (NC)/3DO(NO) to the reverse direction start/stop of the motor.

-As the drawing shown, when the controller receives the forward directional start command (such as 3DI terminal or display interface), 2DO closed(pulse), contactor KM1 power on, the motor start with forward direction.

-When the controller receives the reverse direction start command (such as 4DI terminal or display interface, 3DO closed (pulse)). contactor KM2 power on. the motor starts with reverse direction.

-When the controller receives the stop command (such as 5DI terminal or display interface), 1DO open (pulse),contactor KM1/2 power off, the motor stop

-if enable "Continuous Switching",if the current rotation direction is forward, the controller receives the reverse start signal, the motor will stop than delay 1s and start in



# GATEWAY

Digital Intelligent Power Distribution Solution Provider

<http://en.sfere-elecnova.com>



# S20



Equipment management  
Data calculation  
Protocol conversion  
Off-line cache  
History record



## FUNCTION

S20 series gateways are commonly used for communication control in industrial field. They have the functions of multi-channel data acquisition, multi-protocol conversion, data analysis & calculation and automatic logic control. They also support docking with multiple platforms and flexible WEB configuration.

## APPLICATIONS



## DIMENSIONS

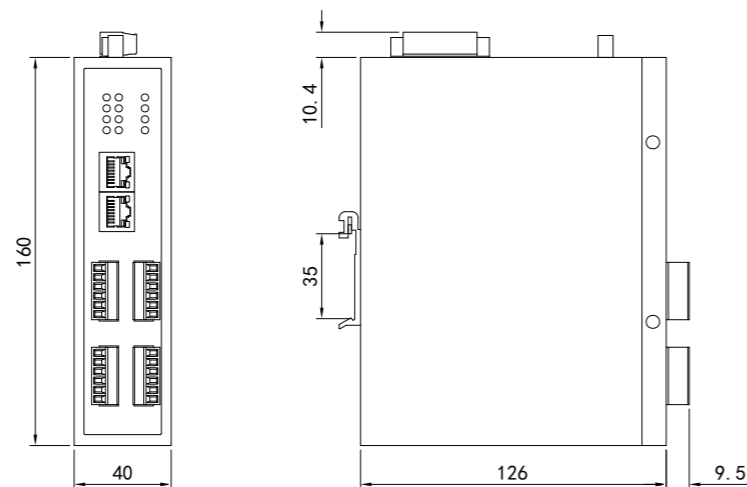

## TECHNICAL SPECIFICATION

Items	S20C4	S20C8
CPU	ARM9	
Uplink	2 Ethernet	2 Ethernet
Downlink	4 RS485	8 RS485
Communication protocol	Modbus-RTU, Modbus-TCP, IEC101, IEC104, MQTT etc.	
Power supply	DC 18~36V	
Power consumption	<5VA	
Working temperature	-25~70 C	

## MAIN FUNCTION

Item	
Multiple protocols	Modbus-RTU, Modbus-TCP, MQTT, IEC104, etc.,
General Modbus RTU/TCP	Modbus register points can be customized to support different byte order.
Device template	Describe devices with multiple protocols.
Database	Built-in Sqlite3 database for data storage and event recording
Web server	Built-in web server, flexible configuration via web browser
Status monitoring	Support to check whether the connected device to the gateway is online or not.
Digital display	The value of the specific point of the online device can be viewed.
Message monitoring	Support to view message information and manual message debugging
Time synchronization	Support NTP and webpage time synchronization
Resume broken-point transfer	After the data upload fails, the data will be cached locally, and the data will be re-uploaded to the platform after the link is restored successfully.
Virtual equipment	Select the required monitoring points and reorganize them into new equipment.



# S15



- Multi-protocol Support
- Multiple Data Point Acquisition
- Event Configuration & Event Recording



S15 is a communication gateway device that can collect multiple protocol buses and upload data to the cloud platform. It has multiple functions such as multi-channel data acquisition, protocol conversion between multiple protocols (Modbus-RTU/TCP, IEC 101/104, MQTT...), simple numerical calculation, automatic logic control, data storage, event recording, offline cache, docking with multiple platforms, flexible WEB configuration, etc.

## MAIN FEATURES

- Message Debugging**
  - Manual
- Programming**
  - Global lua script logic
- Firmware Upgrade**
  - Available via Ethernet

## APPLICATIONS



Smart city



Industrial control



Energy management

## TYPICAL CONNECTIVITY



## DIMENSIONS

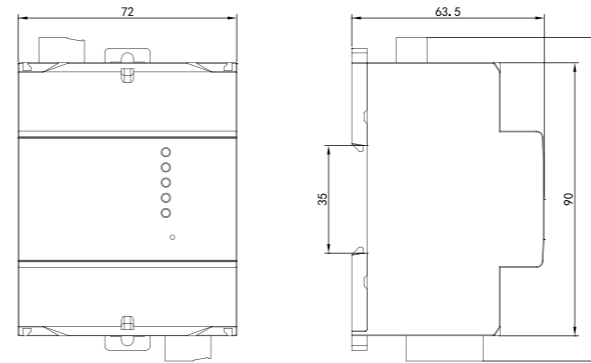

## TYPICAL WIRING

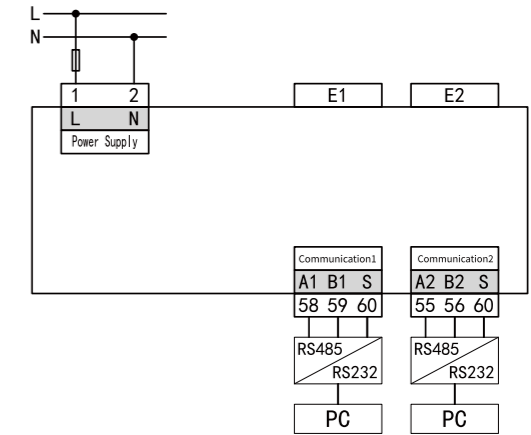

## TECHNICAL SPECIFICATION

		S15-T	S15
<b>Communication</b>	RS485	■	■
	ENET	■	■
	LoRa	□	□
	4G	■	-
	Communication protocol	Modbus TCP/IP, Modbus RTU, MQTT, etc.	
<b>Hardware</b>	RS485	2	
	Ethernet	2 Switch port	
	Working voltage	AC/DC 80~270V 50/60Hz	
	Standard	IEEE 802.3	
<b>Ambient condition</b>	Working temperature	-25~+70℃, ≤95%RH	
	Protection level	IP20	

NOTE: "■": Yes "□": No "□": Optional

# SC2



470M/868M/912M Multi-band  
Wireless Transmission  
Long-range



The LoRa communication gateway uses a serial port for data transmission and reception, which reduces the threshold for wireless applications and can realize one-to-one or one-to-many communication.

## APPLICATIONS



Long distance



Anti-interference



Hardware watchdog

## TYPICAL CONNECTIVITY

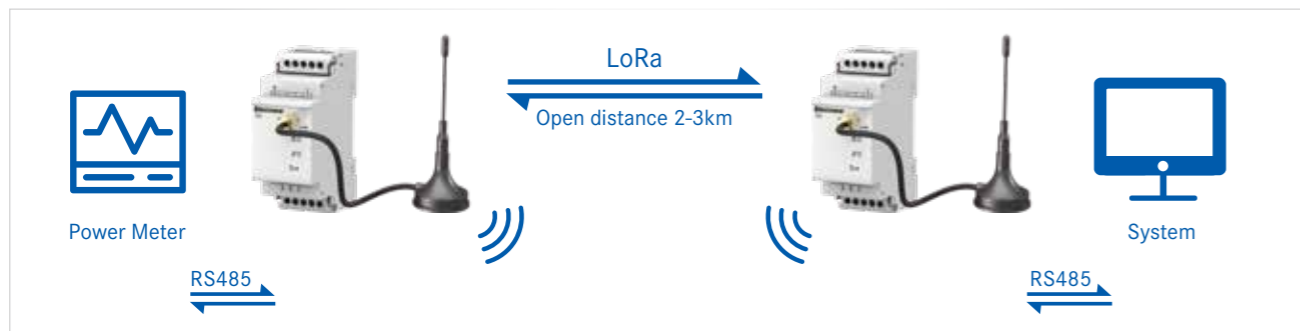

## TECHNICAL SPECIFICATION

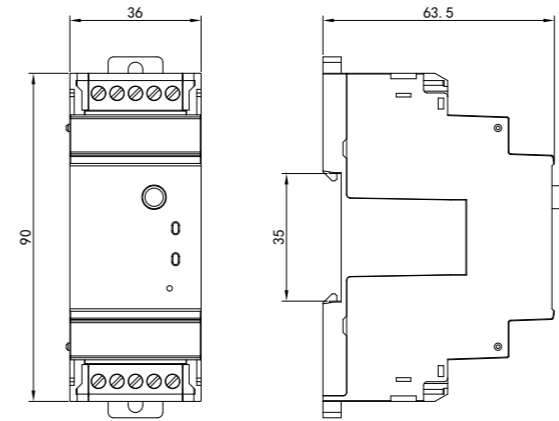

## MODEL DESCRIPTION

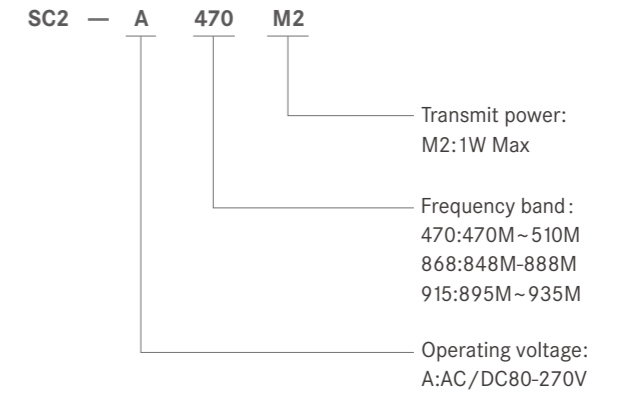

## PRODUCT PARAMETERS

Model	SC2-A470	SC2-A868	SC2-A915
<b>LoRa interface</b>	Working frequency band	470: 470M-510M, 868: 848M-888M, 915: 895M~935M	
	Transmit power	M2: Max.1W	
	Receiving sensitivity	-138dBm@0.3Kbps	
<b>Parameters</b>	RS485interface	Baud rate: 1200bps-115200bps Data format: N.8.1, O.8.1, N.8.2, E.8.1	
	Operating voltage	AC/DC 80~270V	
	Operating temperature	-25°C~70°C	
	Relative humidity	< 95%RH, no condensation	
	Working altitude	< 2000m	
	Anti-pollution grade	No corrosive gas	
	Protection level	IP20	
	Insulation	Signal, power, output terminal to case resistance >100MΩ	
	Withstand voltage	Input and power supply 2kV, input and output 2kV, power supply and output 2kV	
	Insulation	IEC61010-1	

# ELECTRIC INTEGRATION OPERATION PLATFORM EIOP

## EIOP Introduction Concept

- With the help of existing computer and network technology, EIOP provides users with the business services such as intuitive real-time status monitoring, energy consumption data statistics and analysis and event management.
- Through the operation of EIOP, the user's overall level of energy management is improved, the workload of various types of staff in monitoring, management, inspection, operation and maintenance is reduced, the efficiency of human resource is improved, and the costs of energy management, operation and maintenance are reduced.
- Through scientific energy efficiency analysis, EIOP can identify key links of energy consumption, find out weak parts in energy efficiency and excavate energy-conservation potential, which facilitate formulating energy-saving programs and implementing energy-saving measures, in order to reduce energy costs.



### Good expansibility

Extensible business system and system function module to meet users' customized needs



### Advanced and efficient system docking

Support data docking with other third-party intelligent software system



### Convenient configuration

Convenient equipment configuration design and project management



### Reliable

Each business system operates independently



### Safe

Perfect user management operation permission Settings and data backup



### Convenient

Automatic generation of remote meter reading report and data comparison and analysis function



# MOBILE EIOP

APP gives full play to the advantages of mobile and portable and integrates the business functions of web end, which make it convenient for users to grasp the operation status of electrical system anytime and anywhere.

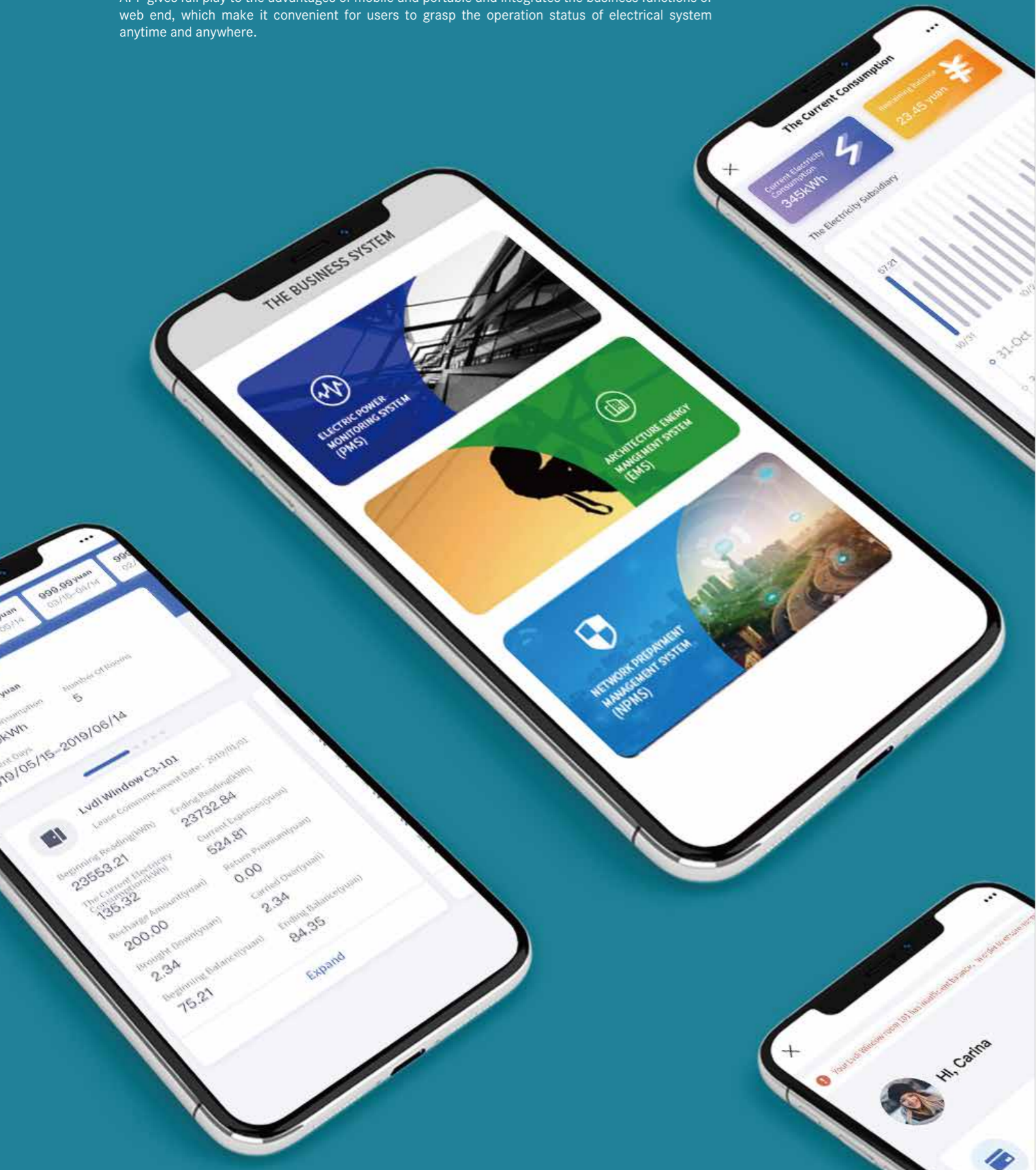

# PLATFORM FEATURE

## Electric Power Monitoring System (PMS)

The power monitoring system (PMS) integrates various terminal hardware such as smart meters, integrated protection devices, smart circuit breakers, and temperature control meters through network communication equipment to achieve business functions such as data collection, remote control, event alarm, and data analysis, in order to improve the comprehensive management level of users' power distribution.



- Ensure the safety of the power distribution system
- Improve daily inspection efficiency
- Identify key control objects
- Reduce overall operating costs

## Network Prepayment Management System (NPMS)

The network prepayment management system NPMS is based on smart meter technology, Internet technology, IT technology and communication technology. This system realizes online monitoring of energy consumption and property charging management with the help of terminal meters.



- Unified platform deployment
- Flexible billing scheme
- Tenant friendly
- Billing design
- Balance alert & Overdraft amount & Ensuring power supply on holidays
- Detailed report records

# PLATFORM FEATURE

## Architecture Energy Management System (EMS)

Architecture Energy Management System (EMS) takes the concept of networking, integration and intelligence as the design concept. It implements centralized monitoring, measurement and management of energy, water, gas and other energy consumed in buildings. It can perform dynamic trend analysis on statistical data of building energy consumption from various dimensions such as classification, item, partition and household so as to help users grasp the status of building energy consumption, analyze and judge building energy efficiency levels. It plays a role in improving energy efficiency, reducing building energy consumption and optimizing building energy use, and provides detailed data to support the excavation of energy-conservation potential and the evaluation of energy-saving benefit.

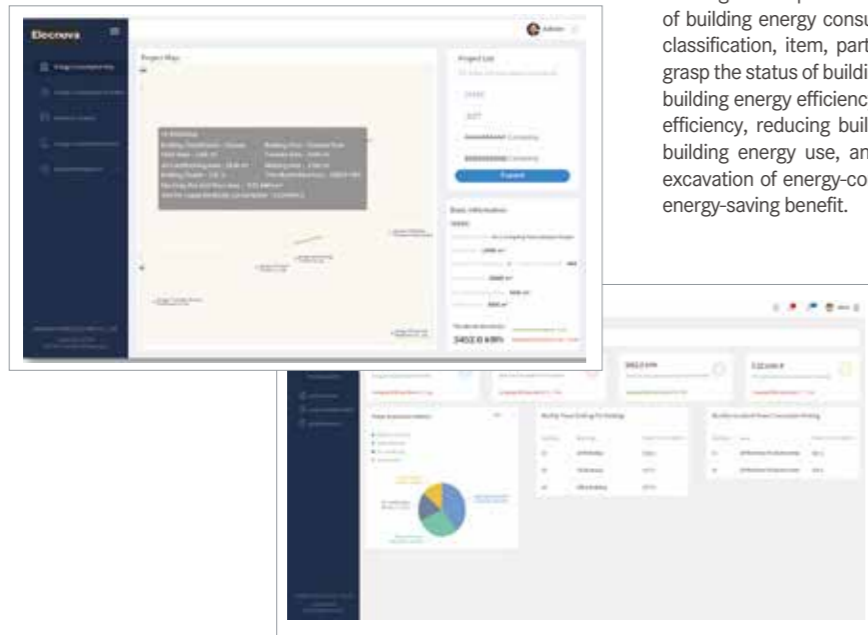





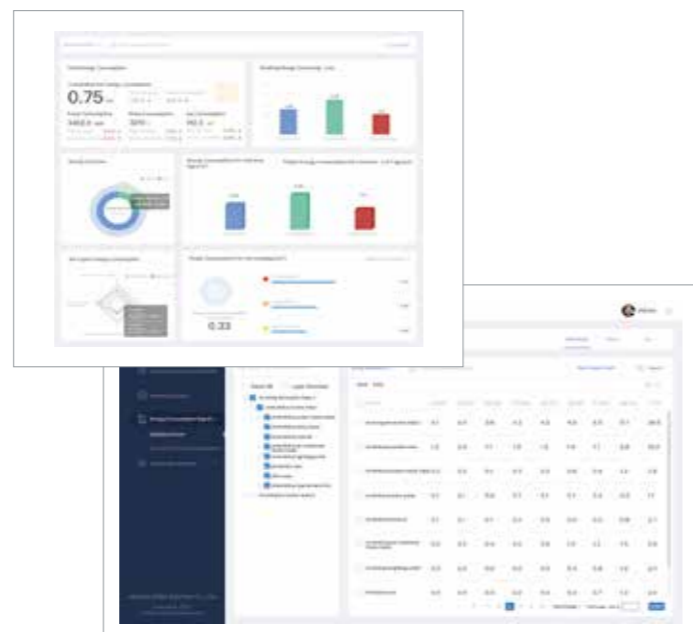







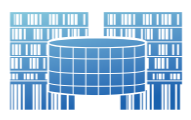

## Architecture Energy Management System(EMS)

- Ensure the safety of the power distribution system
- Improve daily inspection efficiency
- Identify key control objects
- Reduce overall operating costs



# PROJECTS

<ul style="list-style-type: none"> <li>■ Vietnam Viettel Group</li> </ul> 	<ul style="list-style-type: none"> <li>■ Russian VTB Group</li> </ul> 
<ul style="list-style-type: none"> <li>■ Pakistan Gwadar Port</li> </ul> 	<ul style="list-style-type: none"> <li>■ Hong Kong-Zhuhai-Macao Bridge</li> </ul> 
<ul style="list-style-type: none"> <li>■ ST Telemedia Data Center</li> </ul> 	<ul style="list-style-type: none"> <li>■ Shanghai Disneyland</li> </ul> 
<ul style="list-style-type: none"> <li>■ Raffles Medical Group</li> </ul> 	<ul style="list-style-type: none"> <li>■ Thailand Don Mueang Airport</li> </ul> 
<ul style="list-style-type: none"> <li>■ Stock Exchange Data Center in Golden Bridge</li> </ul> 	<ul style="list-style-type: none"> <li>■ Singapore PowerGrid Data Center</li> </ul> 
<ul style="list-style-type: none"> <li>■ Singapore Nanyang Technological University</li> </ul> 	<ul style="list-style-type: none"> <li>■ Indonesia DCI Data Center II, JK5</li> </ul> 
<ul style="list-style-type: none"> <li>■ Hong Kong Hopewell Center</li> </ul> 	<ul style="list-style-type: none"> <li>■ BCA Academy</li> </ul> 

Visit us for more information <http://www.sfere-elec.net>