

# **Elecnova**

## **Pre-payment Electricity Meter with Guiding Rail Type Installation User Manual**

Applicable Model:

DDSY1946A

**JIANGSU SFERE ELECTRIC CO., LTD.**

# Contents

<b>1. Reference Standard</b> .....	<b>3</b>
<b>2. Overview</b> .....	<b>3</b>
2.1 Identification of Code.....	3
<b>3. Model Selection</b> .....	<b>4</b>
<b>4. Technical Parameters</b> .....	<b>5</b>
<b>5. Functional Characteristics</b> .....	<b>6</b>
5.1 Parameter Measurement.....	6
5.2 Electric Energy Metering.....	6
5.3 Rate Electric Energy.....	6
5.4 Meter Reading Function.....	8
5.5 Prepayment Function.....	8
5.6 Step Tariff.....	10
5.7 Malignant Load.....	10
5.8 Electricity larceny prevention function.....	11
5.9 Demand Quantity.....	11
5.10 Event Recording.....	12
5.11 Out-of-limit.....	12
5.12 Preset Electric Energy.....	13
5.13 Input and Output.....	13
5.14 Communication.....	14
<b>6. Installation</b> .....	<b>15</b>
6.1 Wiring Mode.....	15
6.2 Outline Dimension.....	15
<b>7. Operation</b> .....	<b>17</b>
7.1 Panel.....	17
7.2 Display.....	17
<b>8. Setting</b> .....	<b>19</b>

## 1. Reference Standard

GB/T17215.322-2008	Electricity metering equipment (a.c.)-Particular requirements - Part 22: Static meters for active energy (classes 0.2S and 0.5S)
GB/T17215.323-2008	Electricity metering equipment (a.c.)-Particular requirements - Part 23: Static meters for reactive energy (classes 2 and 3)

## 2. Overview

The DDSY1946A electricity meter is designed by adopting advanced microprocessor and signal processing technology, and it possesses functions as below: whole power quantity measurement, electric energy metering, time-division charging, prepayment, demand quantity statistic, event recording, malignant load identification, fault warning, etc. In addition, it is equipped with switching value input, relay output, pulse output and RS485 communication interface. The instrument inner is provided with magnetic latching relay, with the maximum make-break capacity reaching 100A, applicable to power consumption management of commercial real estate, school and intelligent building.

### 2.1 Identification of Code

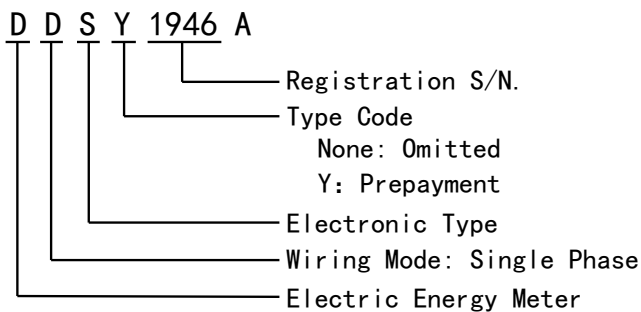

Figure 1 Code

### 3. Model Selection

Function		Model	DDSY1946A
Wiring mode	Single phase		√
Voltage range	230V		√
Current specification	Direct access		5(80)A
Real-time measurement	Voltage and current		√
	Power		√
	Power factor		√
	Frequency		√
Electric energy metering	Two-way electric energy		√
	Multi-rate electric energy		√
Switching value	Switching value input (AC wet contact)		√
	Relay output		√
Communication	RS485 interface		√
Electric energy pulse/Clock pulse			√
Display Mode			LCD

Note: The “√” above means that the item has the corresponding function.

## 4. Technical Parameters

Electrical Characteristics		
Accuracy grade	Voltage and current: 0.2%; Power: 0.5%; Frequency: $\pm 0.01\text{Hz}$ ; Active electric energy: grade 0.5S; Reactive electric energy: Grade 2	
Rated voltage	AC 230V	
Input current	AC 5(80)A	
Frequency	50/60 Hz	
Wiring Mode	Single phase	
Scope of working voltage	$0.8U_n \sim 1.2U_n$	
Power consumption	Power consumption of voltage circuit	< 5VA
	Power consumption of current circuit	< 2VA
Startup current	Direct access	0.004Ib
Switching Value Input		
AC wet contact	ON: AC 180~270V, OFF:< AC 100V	
Communication Characteristics		
RS485 communication interface	Modbus-RTU protocol, maximum baud rate: 9,600bps	
Multi-functional Output Interface		
Electric energy pulse	Pulse width: 80ms $\pm$ 20ms	
Clock pulse		
Tripping Control Output Interface		
Contact capacity	3A/250 VAC; 5A/30 VDC	
Mechanical Characteristics		
Dimension (mm)	90 $\times$ 90 $\times$ 68	
IP protection	IP54 (panel)/IP20 (case)	
Environmental Characteristics		
Working temperature	(-25~70) $^{\circ}\text{C}$	
Storage temperature	(-30~80) $^{\circ}\text{C}$	
Relative humidity	(5~95)%( no condensation)	

## 5. Functional Characteristics

### 5.1 Parameter Measurement

Measure the following parameters in a real-time way:

- (1) Phase voltage: U;
- (2) Current: I;
- (3) Active power: P;  
Reactive power: Q;  
Apparent power: S;
- (4) Power factor: PF;
- (5) System frequency: F;
- (6) Demand quantity, maximum value, and minimum value.

### 5.2 Electric Energy Metering

■ Total electric energy: the electric energy meter can make a statistic of total positive active electric energy, total negative active electric energy, total positive reactive electric energy, total negative reactive electric energy, total apparent electric energy and four-quadrant reactive electric energy.

It supports the function of logic computation of two-way electric energy:

$|EP+| + |EP-|, |EP+|-|EP-|, |EP-|-|EP+|;$

$|EQ+| + |EQ-|, |EQ+|-|EQ-|, |EQ-|-|EQ+|.$

■ Monthly historical electric energy: the electric energy meter can record the current total active electric energy and total active electric energy of the previous 12 months.

■ Daily historical electric energy: the electric energy meter can record the current total active electric energy once at the zero o'clock each day, recording for 92 consecutive days.

■ Hourly historical electric energy: the electric energy meter can record the current total active electric energy each hour, recording for 72 consecutive hours.

### 5.3 Rate Electric Energy

The electric energy meter can make a statistic of tip, peak, flat and valley rate active electric energy.

■ *Rate code*: During the setting, the rate code is adopted to represent what kind of rate the electricity meter is running at, and T1, T2, T3 and T4 are adopted for representation; T1 is corresponding to tip rate, T2 is corresponding to peak rate, T3

is corresponding to flat rate, and T4 is corresponding to valley rate.

- *Time section*: the electricity meter can divide a day into 12 time sections at most. The time sections must be set in a continuous way, i.e. the starting time of this time section is the ending time of last time section.

- *Daily rate*: the instrument can preset 4 sets of schedules of daily rate, and the time section ruled by each set of schedule of daily rate can execute different rates. During the programming, the code of schedule of daily rate is adopted to represent which set of schedule of daily rate of the electric meter is to be executed, and the No. of schedule of daily rate is represented with #1, #2, #3 and #4; #1 is corresponding to the 1<sup>st</sup> set of schedule of daily rate, and so on.

- *Holidays*: Holidays include regular holidays (22 days) and irregular holidays (60 days), totaling 82 days. The regular holidays generally refer to national holidays, which are the same each year, such as January 1 and May 1, which can be customized by the user at will. The irregular holidays generally refer to national holidays which are not the same each year, such as Spring Festival (February 9, 2005), which can be set by the user according to actual holidays each year. The holidays can be executed by selecting any one set among 4 sets of schedules of daily rate at will.

- *Weekly rate*: With regard to 7 days each week, any one set among 4 sets of schedules of daily rate can be selected for execution.

*Special rate of weekly rest day*: the weekly rest day generally refers to the rest day within one week. The function is suitable for occasions having special rate requirements for weekly rest day; in which, Saturday and Sunday all can be set in a selective way. For example, if both Saturday and Sunday are rest days and the special rate and special time section are executed, the special rate can be set in the rate schedule 3, and the special time section can be set in time section schedule 4.

- *Monthly rate*: With regard to each month, any one set among 4 sets of schedules of daily rate can be selected for execution.

- *Priority execution sequence of rate*: the execution mode of rate is divided into two types: holiday rate and basic rate. In case of holiday rate mode, if the day refers to holiday, it is necessary to execute holiday rate, not the basic rate. The basic rate is divided into two types, i.e. weekly rate and monthly rate; in case of weekly rate type, it is necessary to execute the schedule of weekly rate; in case of monthly rate type, it is necessary to execute the schedule of monthly rate.

- *Historical rate electric energy*: the electric energy meter can make a statistic of current total active electric energy of tip, peak, flat and valley rates and total active electric energy of tip, peak, flat and valley rates of the previous 12 months.

## **5.4 Meter Reading Function**

The electric energy meter provides two meter reading modes, i.e. “automatic meter reading for electric energy freezing” and “manual meter reading for electric energy freezing”.

- Automatic meter reading for electric energy freezing: the electric energy meter can store current total electric energy and active electric energy of tip, peak, flat and valley rates according to the set meter reading day each day, and it can store electric energy of 12 months in total.

- Manual meter reading for electric energy freezing: the electric energy meter can record the current total electric energy and active electric energy of tip, peak, flat and valley rates by issuing the command of “freeze electric energy instantly”, and it can record current time, and then conduct storage. It can save the instantaneous frozen electric energy for 3 times at most.

## **5.5 Prepayment Function**

The electric energy meter supports the prepayment working mode of payment first and then power using, so as to provide help for charging users.

The electric energy meter inner is provided with load switch, and it can cut off 80A current at most. In addition, it can match the prepayment system to realize remote prepayment function. The prepayment system supports multiple recharging modes, and the user can conduct recharging in cash directly by going to the management center, or can conduct payment via the third party of platform, such as WeChat and Alipay.

The prepayment function can be enabled or closed via software.

### **5.5.1 Arrearage Warning and Tripping**

When the residual amount is less than the alarm amount, the electric energy meter will display arrearage alarm information to remind the user of charging in time; when the residual amount is less than the arrearage power off threshold, the electric energy meter will trip instantly to stop power supply, and only after charging and when the residual amount is more than the arrearage power off threshold can the power supply continue.



The alarm amount, arrearage power off threshold and tripping relay can be set via software.

### **5.5.2 Charging Function**

The electric energy meter can conduct charging via communication.

### **5.5.3 Overdraft Function**

The electric energy meter has the programmable overdraft function, and it can set overdraft amount (the default value is 0, which means that there is no overdraft function). After enabling the overdraft function, and when the residual amount of the user is less than the arrearage power off threshold, the electric energy meter will not instantly trip to stop power supply, but when the residual amount  $\leq$  arrearage power off amount — overdraft amount, the electric energy meter will instantly stop power supply. The function can be enabled and closed via software.

### **5.5.4 Power Protection during Holidays**

The electric energy meter has the function of programmable power protection during holidays, which can guarantee the power using reliability during holidays for the user, and make sure that there will be no tripping power off during the power protection period. The time section of holidays can be set, and the function can be enabled or closed via software.

When the current time is within the time section scope of the schedule of holidays, the tripping power off logic will be invalid if it is caused by insufficient electric charge or overdraft; however, when the real-time section exceeds the scope of holidays, if the power protection and tripping prohibition ever occur in the past, there will be tripping power off at this time.

### **5.5.5 Free kWh Value**

The electric energy meter possesses programmable free kWh value function, and it can set free kWh value (the default value is 0, which means that there is no free kWh value function, with unit of 1kWh), and it can set the issue date of free kWh value (the default value is 1, which means that the free kWh value is issued on the 1<sup>st</sup> day each month).

For example, when the user sets the free kWh value as 10kWh and sets the date as 1, it means that it is necessary to firstly deduct the 10kWh in case of starting the charging of the next month, and if the residual free kWh value is not deducted to 0, the electric charge amount will not be deducted from the account. The charging

operation will be conducted after the residual free kWh value is 0. The free kWh value is accumulative type, and the value not used in this month can be accumulated to the next month for using.

## 5.6 Step Tariff

The electric energy meter has the step tariff charging function, and it can be set according to the customer's demand, so as to conduct annual step or monthly step charging.

The step tariff can be increased based on current tariff according to the electric quantity of the step which the current power consumption belongs to.

For example, the setting of step tariff parameters is shown as below:

Table 1 Step Tariff Parameters Table

S/N.	Step Electric Quantity/kWh	Step Tariff/RMB	Actual Tariff
0	$x < 10000$	0	Current tariff
1	$20000 > x \geq 10000$	0.5	Current tariff +0.5
2	$25000 > x \geq 20000$	0.8	Current tariff +0.8
3	$x \geq 25000$	1.0	Current tariff +1.0

When the current power consumption is 12,000kWh, it is in the first step, and the tariff refers to the current tariff plus the tariff of step 1.

## 5.7 Malignant Load

The electric energy meter can realize the limit of superpower and super-current, and in which, the power and current threshold value can be set. After identifying malignant load, the instrument will automatically trip to cut off power supply. The power supply can automatically recover after interruption, and the recovery time can be set, with unit of minute.

The electric energy meter can conduct resistive load judgment to newly added load, and the scope of power and power factor of newly added equipment can be set. When the power of newly added equipment is greater than the set value, and the power factor of newly added equipment is greater than the set value, the instrument will identify it as malignant load, and after a certain period of time delay, it will automatically trip for power off. The power supply can automatically recover after interruption, and the recovery time can be set, with unit of minute.

## 5.8 Electricity larceny prevention function

The electric energy meter can measure currents of live line and zero line; after the electric energy meter detects that the zero line current exceeds 10% of live line current, it can be judged that there is electricity larceny behavior; the electric energy meter can conduct electric energy metering to zero line circuit, so as to prevent electricity larceny.

## 5.9 Demand Quantity

The electric energy meter supports two kinds of demand calculation methods: slip interval mode and fixed interval mode, and it can record the peak value of the maximum demand quantity.

Parameters to be measured for demand quantity of DDSY electric energy meter include:

### 5.9.1 Slip Interval:

Select a calculation period of 1-60 minutes (with increment of 1 minute). The first time of refreshing time of demand quantity calculation is at the end of the calculation period, and then, it is necessary to refresh once every minute, and the instrument will provide the demand quantity value at the end of the last calculation period.

The Figure below refers to the calculation method of slip block demand quantity, and the calculation period is 15 minutes.

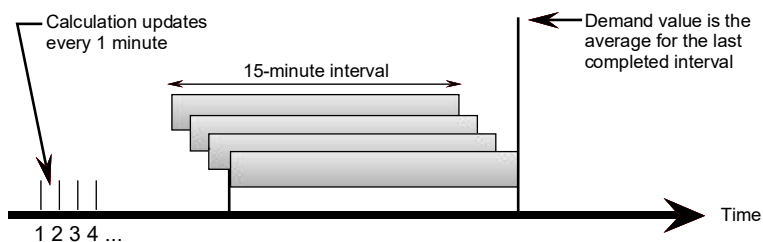

Figure 2 Slip Type Interval

### 5.9.2 Fixed Interval

Select the calculation period of 1-60 minutes (with increment of 1 minute). The

instrument will calculate and refresh the demand quantity value at the end of each calculation period.

### **5.10 Event Recording**

- It can record the number of occurrence times of electrifying, power off, parameter modification, password modification, demand quantity reset, electric energy reset events, as well as the time of the latest record.
- Power purchase recording: It can record the charging time and charging amount of the recent 10 times respectively.
- Extreme value recording: it can record the maximum value and the minimum value of voltage, current, active power, reactive power and apparent power of the history, the month, the last month and the month before last respectively.
- Opening recording: It can record the total number of times of opening and the time of opening of the recent 10 times respectively.
- Closing recording: It can record the total number of times of closing and the time of closing of the recent 10 times respectively.
- Malignant load recording: it can record the total number of times of malignant load and the occurrence time, type and variable value of the malignant load of the recent 10 times respectively.
- Out-of-limit recording: It can record the occurrence time, variable type and variable value of the recent 32 times respectively.

Note: The function involving event recording can be provided with multi-rate function.

### **5.11 Out-of-limit**

The electric energy meter has 8 out-of-limit detection functions, and each one has independent delay time, variable and alarm outlet (relay). Each input quantity can be configured as metering quantity (such as voltage, current, active power, reactive power and apparent power); the output signal refers to relay output, and the relay output supports alarm level and pulse output.

According to on-site using demand, the out-of-limit alarm supports the “and” logic, and it divides the 8 out-of-limit alarm settings into 4 groups; the alarm output will not be started up unless two alarm conditions of the same group are established at the same time after the “and” logic relationship is enabled; and in case that the

“and” logic relationship is not enabled, two alarm outputs of the same group are independent to each other, without mutual influence.

Grouping of 4 groups of “and” logic: out-of-limit 1-2, out-of-limit 3-4, out-of-limit 5-6, and out-of-limit 7-8.

## **5.12 Preset Electric Energy**

The electric energy meter can preset electric energy, mainly meeting requirements of replacing fault meter, household exchange and partial reconstruction items, and set initial electricity value targeting newly replaced or newly installed instruments. The electric energy meter can preset positive/negative active electric energy, positive/negative reactive electric energy, and time-division positive active electric energy.

The preset electric energy value can be preset via RS485 communication.

## **5.13 Input and Output**

### **5.13.1 Input**

1 circuit of active switching values are selected for inputting, so as to reflect the status of external circuit breaker, and see the wiring diagram for detailed wiring mode.

### **5.13.2 Relay**

The electric energy meter provides 1 circuit of relay control and 1 circuit of built-in magnetic latching relay, with the maximum make-break capacity reaching 100A; in which, the built-in magnetic latching relay can directly control power on and power off of the user, and the externally controlled relay can be used to control opening/closing of external circuit breaker, thus indirectly controlling power on and power off of the user. The relay under the cooperation of prepayment function can realize the control of power consumption of the user, and also can realize alarm together with the alarm function. In addition, it can be related to the malignant load identification function, thus realizing malignant load tripping function.

Control mode: automatic control/remote control;

“Automatic control” means that the prepayment electric energy meter judges on and off according to the amount in the meter;

“Remote control” means that the magnetic latching relay is to be controlled remotely;

### 5.13.3 Multi-functional Port

The multi-functional port can be used as second pulse or active electric energy pulse output, and the user can set it via software.

When the multi-functional port of electric energy meter is used as active electric energy pulse output, it adopts the optical coupling collector open-circuit mode to realize remote transmission of active power, and the remote computer terminal, PLC or switching value collection module collects the total pulse number of instrument to realize accumulative metering of electric energy.

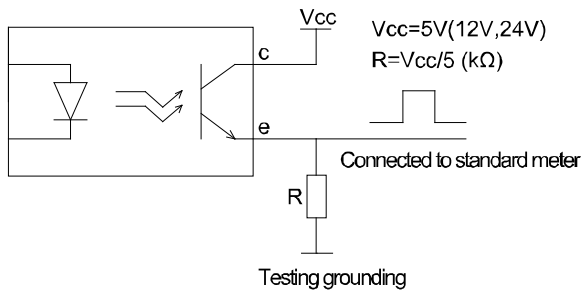

Figure 3 Schematic Diagram of Testing of Electric Energy Pulse

### 5.14 Communication

- The RS485 interface and the electric meter inner are of electrical isolation, and there is lightning protection circuit in the design.
- The PC computer can be adopted for RS485 communication, so as to complete programming setting and meter reading.
- The communication protocol is defaulted as Modbus-RTU protocol, and it can be modified into DL/T645-2007 protocol via pressing relevant keys.
-

# 6. Installation

## 6.1 Wiring Mode

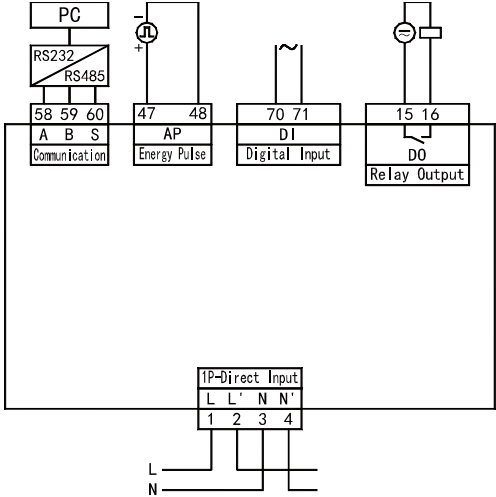

## 6.2 Outline Dimension

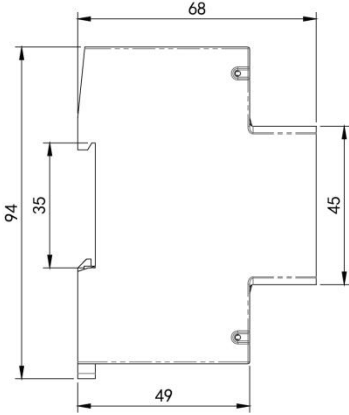
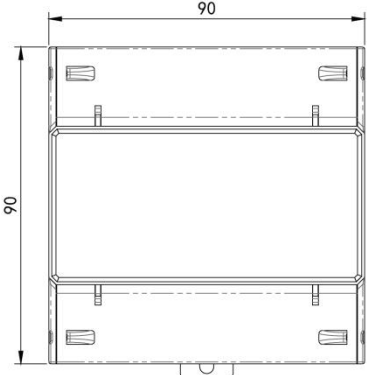

## 6.3 Installation Method

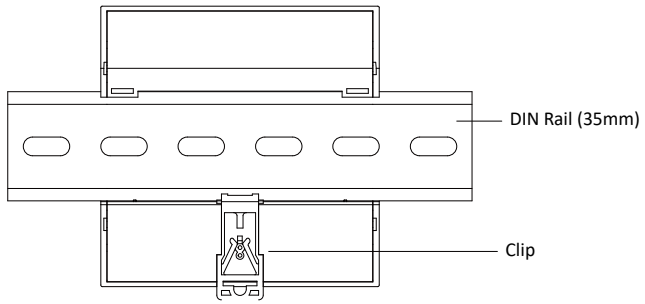



## 7. Operation

### 7.1 Panel

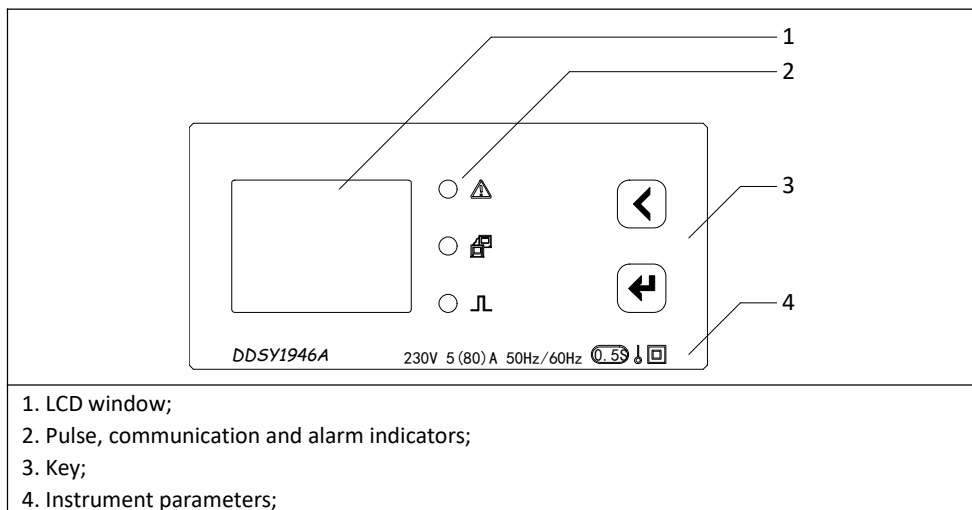

### 7.2 Display

The electricity meter can display electric quantity data and electric energy data such as voltage, current, power, power factor and frequency. After pressing “←” or “←→” key, various data interfaces can be switched towards left or right.

Overview of display interface:

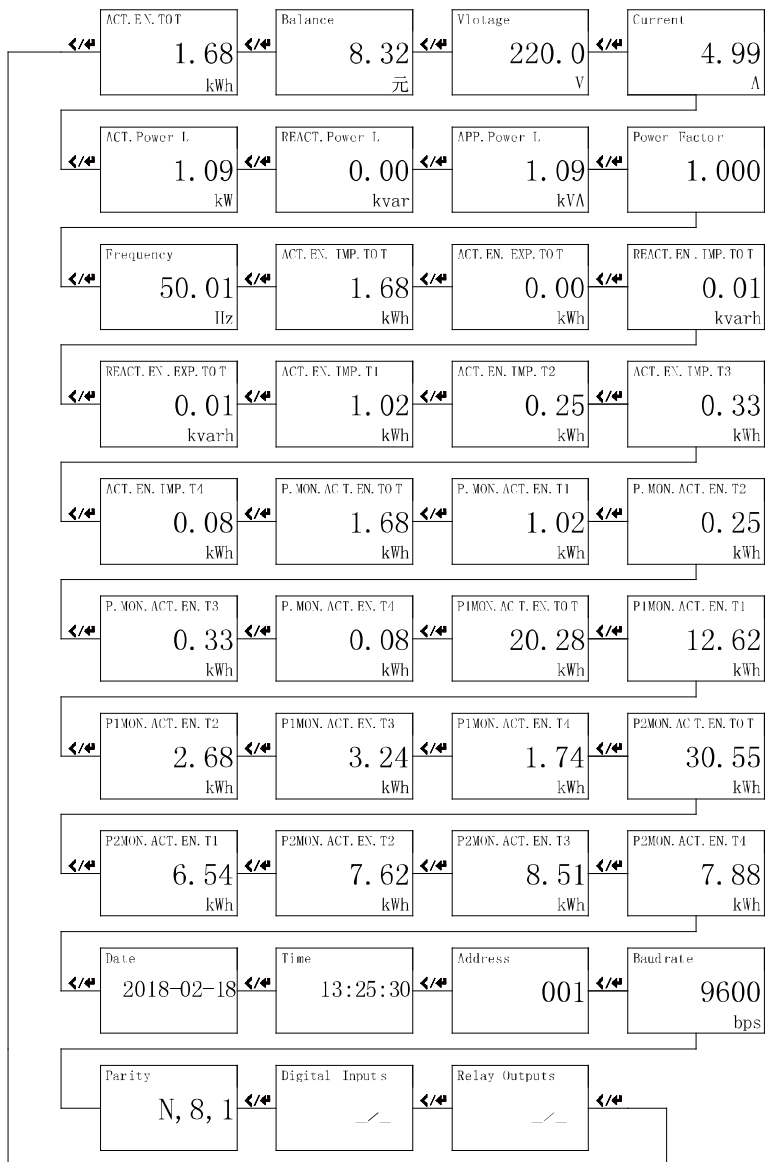

## 8. Setting

The instrument has 3 keys, and 2 of them on the panel are “**Modification Key**” and “**Confirmation Key**”, while the other is below the protection cover of terminal, called “**Programming Key**”. Their functions are shown as below:

### “ **Modification Key**”

A: Conduct switching of menus at the same level. Click the key on the display interface to display measurement data in a circulating way; on the setting interface, the key can be used to switch various options of menus at this level.

B: Modify the value of single data bit. On the value setting interface, click the key and then the value will change within 0-9 in a circulating way.

### “ **Confirmation Key**”

Switch data bit and conduct confirmation. The key is used to switch various data bits of the value. Click it once, then it will switch one bit towards left, and at the same time, the value in this bit will flicker; in case of switching to the largest bit, click the “**Confirmation Key**” again to save the setting parameters, and then return to the previous level of menu.

### “**Programming Key**”

Long press this key to enter the parameter setting interface.

#### **Entering Programming Mode**

Long press the “**Programming Key**” on the display interface for longer than 3 seconds, and then there will be “Input password”; input the password (default 0001) via “**Modification Key**” and “**Confirmation Key**”, enter the setting interface if the password is correct; otherwise, the interface will stay in case that the password is wrong.

#### **Quitting Programming Mode**

At the first level of menu, click the “**Modification Key**” to switch to the menu “Save parameters”, and click the “**Confirmation Key**” to select “Yes”, thus saving the made modification and quitting; in case of selecting “No”, the modification will not be saved prior to quitting, thus returning to the measurement display interface.

## Value Modification

The “**Modification Key**” is used to modify the value of single data bit, and click this key, the value will change within 0-9 in a circulating way. The “**Confirmation Key**” is used to switch among various data bits of the value, and when some bit is switched to, the value on this bit will be of reversed display, while in case of switching to the largest bit, click the “**Confirmation Key**” again to save the setting parameters, and then return to the previous level of menu.

Overview of Setting Menu:

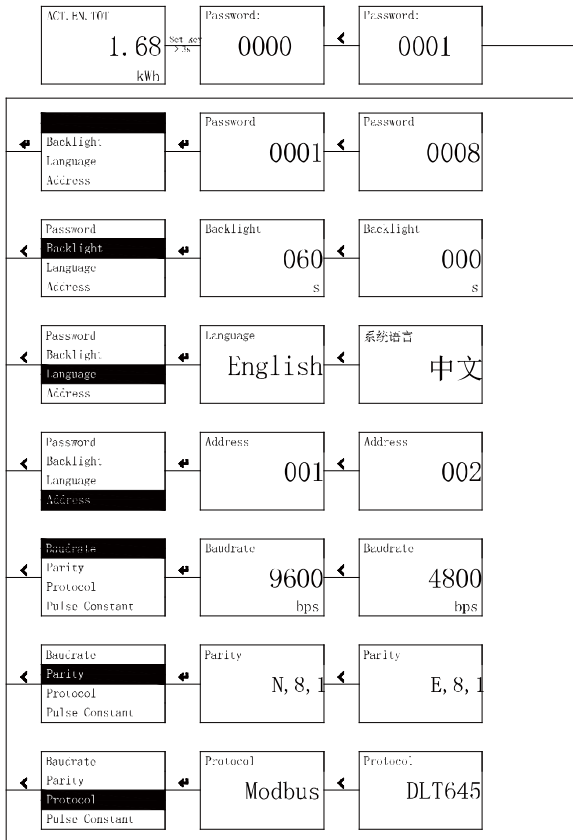

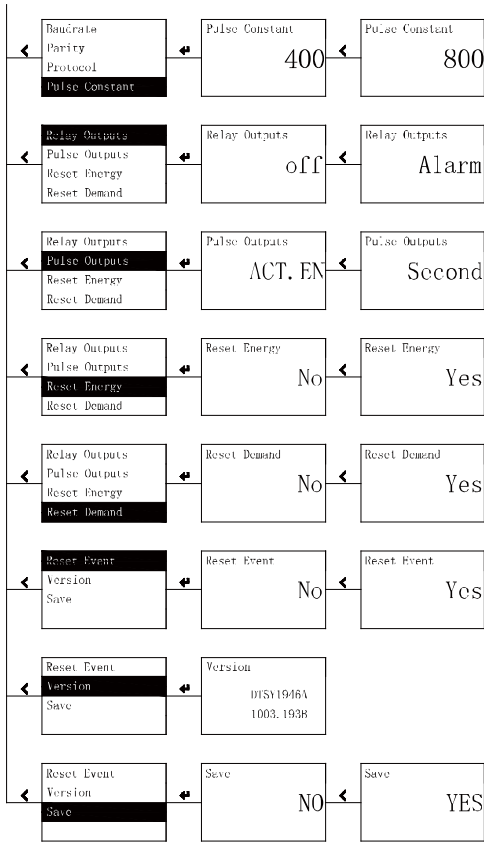

System parameter setting and communication parameter setting:

In which, the communication parameter setting part sets the communication address as 2, sets the baud rate as 9,600, and sets the check mode as E.8.1; in addition, it sets the communication protocol of DLT645.

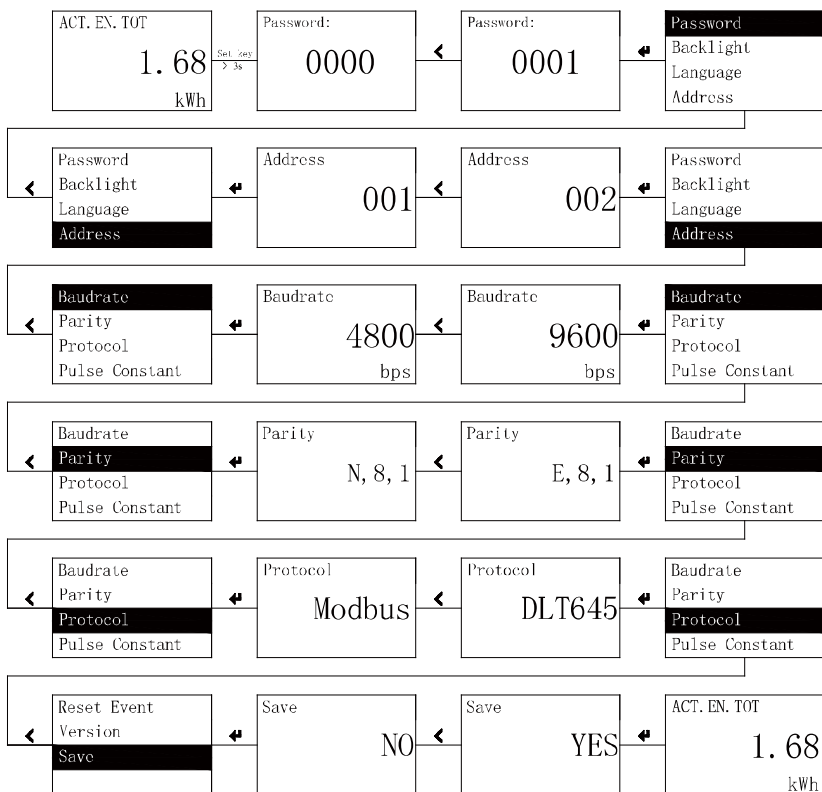

---

The information in this document is subject to changes without any further notice.

**JIANGSU SFERE ELECTRIC CO., LTD.**

**Add: 1 Dongding R., Jiangyin, Jiangsu, China.**

**P.C: 214437**

**Tel: 0086-510-86199063**

**Fax: 0086-510-86199069**

**http: //www.sfere-elec.com**

**Email: export@sfere-elecnova.com**